



Design of soil steel composite bridges

Lars Pettersson Håkan Sundquist

TRITA-BKN. Report 112, 5th Edition 2014
ISSN 1103 - 4289
ISRN KTH/BKN/R--112--SE

Structural Design and Bridges, 2007
KTH, Civil and Architectural Engineering
KTH, SE 100 44 Stockholm
www.byv.kth.se

Design of soil steel composite bridges

Lars Pettersson Håkan Sundquist

TRITA-BKN. Report 112, 5th Edition 2014
Structural Design & Bridges 2007
ISSN 1103-4289
ISRN KTH/BKN/R- - 112 - - SE

Copyright dept. for architectural and civil engineering, KTH
Stockholm 2007, Fifth edition 2014

The picture on the cover page is a SuperCor Soil-Steel Composite Bridge over a small stream “Skalvattsbäcken” in northern Sweden

Preface

This manual is intended to be used for the design of flexible metal culverts and bridges exposed to traffic and other loads.

The investigations which are used as a base for this manual have been conducted by the undersigned and commissioned by the Swedish Transport Administration (*Trafikverket*), earlier the Swedish National Road Administration (*Vägverket*), the Swedish Rail Administration (*Banverket*) and also ViaCon AB.

The manual is intended to be used, together with complementary instructions issued by the respective authorities, in practical design and the manual therefore contains design aids and examples. In the examples, the proposed partial safety factors are only example values and may only be used with the consent of the authority in question.

A special thanks is expressed to Jan Vaslestad, PhD, Norwegian Public Roads Administration who has offered comments and suggestions for improving the text.

Figures have been constructed by civ. ing. Hector Valenzuela and Håkan Sundquist.

Stockholm, September 2001

Lars Pettersson Håkan Sundquist

Preface to the English version of the third edition of the Swedish manual

This English version of the handbook is a revised version of the third Swedish edition of the handbook “Dimensionering av rörbroar” (Design of long-span flexible metal culverts). The manual has been renamed after a suggestion by Baidar Bakht, PhD, clearly pointing out that this kind of structure really is a composite structure where the soil and the metal structure are cooperating in withstanding the loads.

Compared with earlier version the manual incorporates the results of further full-scale tests on metal culverts, both on “normal” types and on so-called “box culverts”. This mean that box culverts can now be designed in accordance with this manual, and that certain modifications have been introduced into the analytical methods. In addition, regulations for helically corrugated pipes have been included in these instructions. In order to increase the understanding of the principles adopted, additional explanations of some of the equations have been incorporated into the text. The background to several of the changes has been developed by Lars Hansing MSc, Viacon AB.

In this English version of the third edition some information has been added making it possible to use the handbook in combination with Eurocode 3.

This English version is a revision and extension by Anthony Bristow PhD of the earlier translation of the second edition made by Gerard James PhD.

Stockholm, June 2007

Lars Pettersson Håkan Sundquist

Preface to the fourth edition of the manual

This fourth edition has been updated regarding the following points

- New rules for the minimum distance between parallel pipes. These rules are based on Canadian experience.
- Larger compression forces are proposed for culverts with small radius of curvature at the corners.
- Revised formulas are proposed for the design moment due to traffic loads.
- New text for checking the structural capacity of existing structures is added.

Some minor editing revisions have been carried through.

Stockholm, January 2010

Lars Pettersson Håkan Sundquist

Preface to the fifth edition of the manual

This fifth edition has been updated regarding the following points

- The manual is now fully based on the Eurocodes.
- A new section on fatigue design has been added. This section is based on new tests and new research.
- Notations are changed to comply with the rules in Eurocode and the ISO Standards
- The text for checking the structural capacity of existing structures is completed and revised.

MSc and PhD student Amer Wadi has developed new diagrams for fatigue design, checking the capacity of existing structures and also made some revisions of the design load diagrams. He has also helped in editing of the report.

Stockholm, October 2014

Lars Pettersson Håkan Sundquist

Contents

1.	Introduction	1
1.1	General	1
1.2	Area of validity	2
1.2.1	Notations	2
1.2.2	Calculation and design methods	3
1.2.3	Accepted culvert profiles	4
1.2.4	Soil material requirements	9
1.2.5	Minimum distance between adjacent pipes	10
1.2.6	Miscellaneous information	12
2.	Design and construction of culverts	13
2.1	General	13
2.1.1	Durability and lifetime	13
2.2	Preliminary design of culverts	13
2.2.1	Geotechnical investigations	13
2.2.2	Documentation	14
2.4	Aesthetical design of soil steel composite bridges	15
3.	Principles for analysis	16
3.1	General conditions	16
3.2	General calculation principles	16
3.3	Limitations	17
3.4	Characteristics of the structural backfill	17
3.5	Live loads	18
3.5.1	Dynamic amplification factor	18
3.6	Cross-sectional properties	19
4.	Load effects	20
4.1	General	20
4.2	Risk for local failure at very small cover depths and a minimum height of cover	20
4.3	Effective height of cover	20
4.4	Normal forces	20
4.4.1	Sectional forces due to the surrounding soil	21
4.4.2	Evenly distributed traffic loads	23
4.4.3	Concentrated traffic loads	23
4.4.4	Calculation of the equivalent line load, p_{traffic} and the normal force due to traffic	24
4.4.5	Design normal force	25
4.5	Bending moments	26

4.5.1	General	26
4.5.2	Bending moments due to the surrounding soil	27
4.5.3	Bending moments due to traffic load	30
4.5.4	Distribution of moments in a culvert with varying cross-section	33
4.5.5	Design bending moments	35
5.	Design	36
5.1	Verification of the load-bearing capacity	36
5.2	Checks in the serviceability limit state	37
5.2.1	Ensuring safety against the onset of yielding in the serviceability limit state	37
5.2.2	Settlements in the surrounding soil	37
5.3	Checks in the ultimate limit state	37
5.3.1	Check against the development of a plastic hinge in the upper part of the pipe.	37
5.3.2	Check for sufficient capacity in the lower part of the pipe	39
5.3.3	Ensuring safety against exceeding the capacity of the bolted connections	40
5.3.4	Check that the radial soil pressure against the lower corner plates is not too big	41
5.3.5	Check of the concrete or steel foundation slabs (arch type culvert profiles and box culverts only)	42
5.4	Fatigue design	42
5.4.1	General and fatigue soil modulus	42
5.4.2	Load actions used for fatigue design of road bridges	43
5.4.3	Fatigue capacity of the steel plates	43
5.4.4	Fatigue capacity of the bolted connections	44
5.5	Construction stage	45
5.5.1	Check to ensure that the construction has adequate rigidity during installation and handling etc.	45
5.5.2	Check of the structure at zero cover depth	45
5.5.3	Check of the structure in temporary construction stages	45
6.	References and literature	46
6.1	References	46
6.2	Literature	50
Appendix 1 - Cross section parameters for some common types of corrugation and plate thickness		51
Appendix 2 - Characteristic soil modulus		57
Appendix 3 - Calculation of the upward deflection of the crown during backfilling		61

Appendix 4 - Live load distribution	62
Appendix 5 - Second-order theory	68
Appendix 6 - Railway load	71
Appendix 7 - Checking the structural capacity of existing SSCB structures	74
Appendix 8 - Design diagrams for different fatigue design loads	81

Notations¹

Latin lower case

a	distance between parallel conduits (Section 1.2.3), distance between bolt and steel plate edge (Section 5.3.3) (m) ²
a_6, a_7, a_{nom}	minimum distance between parallel conduits (m)
a_1, \dots, a_5	dimensions used to define the pipe-soil structure geometry (m)
c	wave length of steel section (m)
d_n	particle size which represents the passing weight of $n\%$ on a gradation curve
d_{bolt}	diameter of bolt (m)
d_x, d_y	dimensions of the wheel contact area (m)
e_0	void ratio
e	calculation parameter, see Appendix 1
f_1, \dots, f_7	functions used as a means of simplification
f_h	function used in calculation of crown rise during construction
f_{index}	<i>stress</i> , see the different indices used at the end of notion section
f_{index}	strength of steel materials and bolts (MPa). Indices used in accordance with EN 1993-2 are described in the text of the relevant sections
f_m	factor for reducing the structural capacity for closely spaced culverts
h	height of culvert profile including corrugation
h_b	ballast thickness (m)
h_c	height of cover (m) (= minimum distance between the top side of the pipe (corrugation) and top side of the surface, e.g. the road surface, at the load point where this distance is smallest)
$h_{c,\text{red}}$	for calculation purposes, a reduced value of the height of cover (m) taking into consideration that the pipe's crown rises during back-filling.
h_{corr}	height of corrugation, applicable to culverts of corrugated sheet metal (mm). For definition, see Appendix 1.
h_f	vertical position of bolt (m)
k_{yy}	interaction factor
k_v	factor used when calculating the tangent modulus
m	modulus number
m_t	tangent length (m). For definition see Appendix 1

¹ In this report we have attempted to follow the international principles for notation and type setting writing style prescribed in "ISO Standards Manual, ISO 31. Quantities and Units",

² The most common unit for the quantity is given in brackets.

n	number
p	pressure between pipe and soil ³ (kN/m ²)
p_t	radial pressure acting on the top plates
p_c	radial pressure acting on the corner plates
p_a	reference pressure (kN/m ²)
p_{traffic}	equivalent traffic load (line load) (kN/m)
q	distributed pressure from traffic (kN/m)
r_d	reduction factor for the dynamic amplification factor
s	distance (m)
t	thickness of sheet metal (mm)
w	centreline length (mm)
w_y	parameter
x, y, z	coordinates

Latin upper case

A	cross-sectional area (m ²)
$A_{\text{bolt}}^{\text{net}}$	tensile stress area of bolt (m ²)
A_{bolt}	area of bolt, (m ²)
$C_{\text{my}} = C_{\text{my},0}$	correction factor, see Section 5.3.1
C_u	uniformity coefficient
C_{yy}	Parameter, see Section 5.3.1
D	diameter or span (m) (the dimension relates to the distance between the centres of gravity of the cross section. Note that the free span is often indicated in technical documentation)
D_A	Parameter, see Appendix 7
E_{soil}	tangent modulus of the soil material in the structural backfill (MPa)
$E_{\text{soil},d}$	design value of the tangent modulus of the soil material in the structural backfill (MPa)
$E_{\text{soil},\text{FAT},d}$	design value of the tangent modulus of the soil material in the structural backfill to be used in fatigue analysis (MPa)
$E_{\text{soil},\text{SLS},d}$	design value of the tangent modulus of the soil material in the structural backfill to be used in the serviceability limit state (MPa)
$(EI)_{\text{steel}}$	the bending stiffness of the wall of the pipe/conduit (MNm ² /m)
$F_{v,\text{Rd}}$	design value of the shear capacity of the bolts in the event of failure in the

³ Different indices may occur.

	sheet metal (kN)
$F_{t,Rd}$	design value of the tensile capacity of the bolts (kN)
$F_{b,Rd}$	design value of the shear capacity of the bolts in the event of failure in the bolts (kN)
H	vertical distance between the crown centre of gravity line of the pipe and the height at which the culvert has its greatest width (opening/span) (see Figure 1.3) (m)
I	moment of inertia of the pipe per metre length of pipe (mm^4/m)
I_D	factor used for analysing the relative degree of compaction
L_ϕ	effective length used for deciding the dynamic amplification factor, compare Appendix 6 .
$M_{Ed}, M_{soil}, M_{traffic}$	design moment, moment due to soil load, moment due to traffic load, respectively (kNm/m), observe different indices
M_u	plastic moment capacity (kNm/m)
N	axial force in pipe (kN/m)
N_{cr}	buckling load for a buried pipe (kN/m)
$N_{cr,el}$	buckling load for a buried pipe under ideal elastic conditions (kN/m)
$N_{soil}, N_{traffic}$	normal force due to soil load and normal force due to traffic load (kN/m)
N_{Ed}	design normal force
N_u	normal force capacity of a fully plasticized cross-section (kN/m)
P	concentrated load (kN)
Q	axle load
R	radius of a circular culvert (m)
R_b	bottom radius (m), see Figure 1.3
R_c	corner radius (m), see Figure 1.3
R_{cr}	critical radius (cf. critical buckling length of an axially loaded column)
RP	relative degree of compaction (%) given as the Standard Proctor unless otherwise stated
R_s	side radius (m), see Figure 1.3
R_t	top radius (m), see Figure 1.3
S_{ar}	reduction factor due to arching effect for load from the overburden
S_v	calculation parameter
W	section modulus (mm^3/mm)
W^*	ratio, see Appendix 7
Z	plastic section modulus (mm^3/mm)

Greek lower case

α	angle used for definition of cross-section
α_c	calculation parameter
α_Q	national chosen reduction parameter for traffic load
β	exponent
χ_y, χ_z	reduction factors, see Section
δ_{crown}	the vertical displacement of the crown of the culvert during structural back-filling
ε	dynamic load allowance (%), $1 + \varepsilon =$ dynamic amplification factor (dimensionless)
γ	partial safety factor (occurs with several different indices ⁴ see also the table below)
η	Z/W
η_s	calculation parameter, see Appendix 5
η_j	calculation parameter, see Appendix 5
η_m	stiffness parameter used in conjunction with judging of the stiffness during installation
ν_{soil}	poisson's ratio for soil
λ_f	stiffness parameter which indicates the relationship between the stiffness of the pipe and that of the surrounding soil (dimensionless)
$\bar{\lambda}_y$	slenderness ratio, see Section 5.3.1
ρ_{surr}	weight density ⁵ of the soil material up to the height of the crown (structural backfill), see Figure 1.4 (kN/m^3)
$\rho_{h_c+H/2}$	mean weight density of the soil material within the region $(h_c + H/2)$, see Figure 1.4 (kN/m^3)
ρ_{cover}	mean weight density of the soil material above the height of the crown within the region h_c , see Figure 1.4 (kN/m^3)
ρ_{opt}	optimum density determined according to the Standard Proctor method (kN/m^3) ⁶
ρ_s	real weight density of the soil material in the backfill, a commonly used value for coarse grain soils is $\rho_s \approx 25 - 26 \text{ kN/m}^3$
φ	angle of internal friction (see footnote 3)

⁴ The index k is used for characteristic, d for design properties and the index cover is used in conjunction with the cover.

⁵ "Weight density" or "unit weight" is used for density multiplied by the acceleration of gravity = $9,81 \text{ m/s}^2 \approx 10 \text{ m/s}^2$

⁶ Usually the proctor method considers densities not weight (unit) densities, but since the proctor methods only consider the quotient between densities it is ok to use either density or unit density.

κ_1	calculation parameter, see Section 4.4.1
κ_2	calculation parameter, see Appendix 5
μ	calculation parameter, see Appendix 5
σ	stress (MPa, kN/m ²)
σ_v	vertical pressure (kN/m ²)
ω	buckling force ratio
ξ	calculation parameter, see Appendix 5

Example of indices used

bolt	bolt
cover	cover
d	design value
E	(load) effect
el	elastic
f	fatigue
FAT	Fatigue Limit State
k	characteristic value
M	material
max	maximum
min	minimum
mod	modified
R	resistance
s	serviceability
SLS	Serviceability Limit State
soil	soil
steel	steel
std	standard
surr	surround
t	top, tension
traffic	traffic
u	ultimate
ULS	Ultimate Limit State
y	yield

Remarks regarding partial coefficients: the indices shown above are used generally, but some clarifications are discussed below

γ_M	Material partial coefficient	
γ_d	Partial coefficient for safety class, see <i>EKS 9</i> or <i>TRVFS 2011:12</i> .	Class 1, 0,83 Class 2, 0,91 Class 3, 1,0
γ_n	Partial coefficient for safety class used in older Swedish standards, see Appendix 7	Class 1, 1,0 Class 2, 1,1 Class 3, 1,2

Definition of concepts important for the design method:

<i>Soil Steel Composite Bridge</i>	A bridge which, through interaction between a flexible pipe and the surrounding soil, provides the required bearing capacity, see Figure 1.2 .
<i>Backfill</i>	The soil which after excavation and the placement of the pipe is back-filled around the pipe. The word is also used to describe the operation of backfilling.
<i>Engineered soil/backfill or structural backfill</i>	The <i>part of the backfill</i> upon which special geotechnical demands are placed, so that the desired interaction between the pipe and the soil is achieved. The phrase is also used to describe the work involved in creating the structural backfill.
<i>Multiple-plate structure of steel</i>	A multiple-plate unit structure which consists of steel sheet metal (usually corrugated) and is joined together by bolted connectors.
<i>Pipe (conduit)</i>	The part of the culvert which consists of corrugated steel plates.
<i>Arching</i>	The transfer of pressure or load between the soil masses above the pipe which arises from the pipe's flexibility.
<i>Steel arch</i>	An arch of corrugated steel plates founded on concrete or steel footings.
<i>Helically corrugated pipe culvert</i>	A culvert where the pipe is made of a steel band in a continuous process where the sheet is corrugated and the steel band is joined along its edges by locked seams.

1. Introduction

1.1 General

This manual presents analysis models and methods for the design of soil steel composite bridges. Both new and existing structures can be analyzed using this manual. An example of this type of structure is flexible culverts made up of corrugated steel sheets in composite action with the surrounding soil. The analysis methods presented was originally based on the Swedish standard for steel structures *BSK 99* and was applied for the Swedish bridge standards *ATB Bro 94* and *ATB Rörbroar*. This manual has now been adapted to Eurocode and the Swedish Bridge Standard *TRVK Bro 11* and recommendations *TRVR Bro 11* and can be applied for other standards by adjusting the partial coefficients in the standard at hand and the soil and other parameters for local conditions. The manual can also be used for other structures than what could be considered “bridges” and thus following the general standards for buildings. The design methodology is however the same. The design theory where the soil acts both as load and as a stabilizing media makes this simplification possible. The design method examples presented are based on Swedish standards for i.e. plate profiles, bolts and tolerances. The standards and tradition might be different in other countries. The relevant regulatory authority in the country at hand, might thus issue complementary rules, i.e. partial coefficients, for using this manual.

Throughout this report, the term culvert is used to describe a bridge which consists of a pipe or an arch usually made of corrugated metal plates which, together with the surrounding compacted soil, form a structure capable of carrying a load. This type of structure is often referred to as a multiple structure since the pipe profile is created by bolting curved and straight metal plates together. In some cases, the pipe is made of helically corrugated sheet metal. An essential requirement is that the sheets are sealed together so that there is a complete static interaction between the segments or metal sheets of which the structure is built. This manual can in principle also be used for other types of flexible tubular structures whose load-bearing capacity is achieved by interaction with the surrounding compacted soil. An example of a common type of layout is shown in **Figure 1.1**.

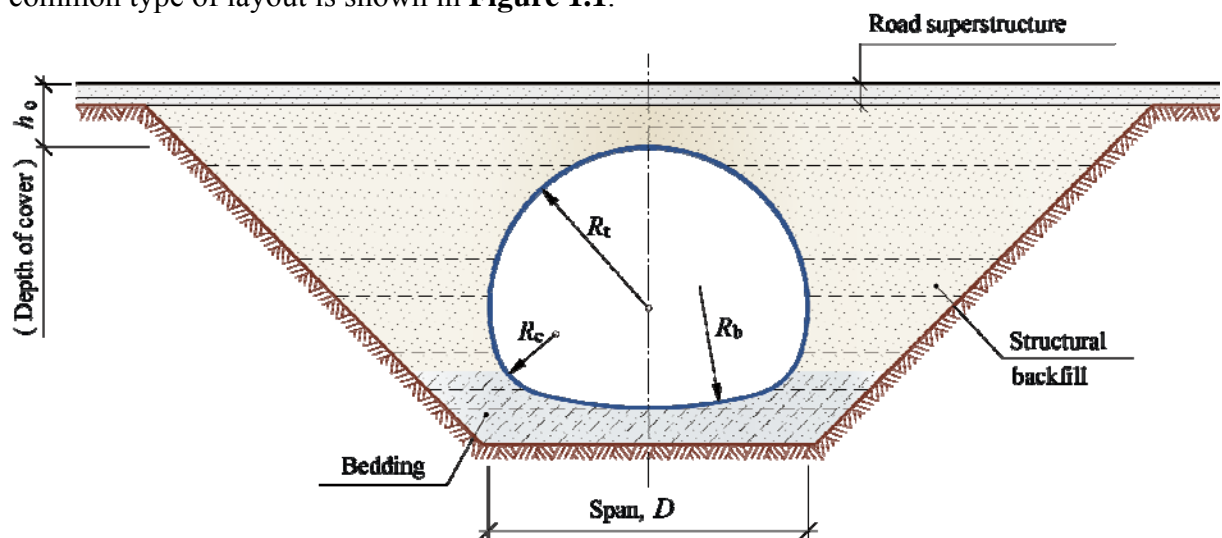

Figure 1.1 Typical layout of a pipe arch culvert of corrugated sheet metal. Careful compaction of the soil around the culvert is important in order to achieve the desired interaction between the pipe and the soil.

A culvert is often a cost-effective solution in many situations where a small waterway, road or railway is required to pass under a road or railway. In these cases, the culvert has the form of a “cut and cover” tunnel. There is no well-defined distinction between what is regarded as a tunnel and what is regarded as a culvert, but, it should be possible, from a strength point of view, to use this manual for the structural design of long tunnels built in the same manner as culverts.

The manual is designed so that a large number of parameters that are significant in the design of culverts can be taken into consideration. Although the manual is primarily directed towards culverts made of corrugated steel sheet metal, it should be possible to use the design methods proposed for other structures, provided they consist of flexible pipe-like structures stabilised by surrounding soil. Methods for checking the structural capacity of existing structures are presented in **Appendix 7**.

1.2 Area of validity

1.2.1 Notations

Some important notations are shown in **Figure 1.2** and **Figure 1.3**.

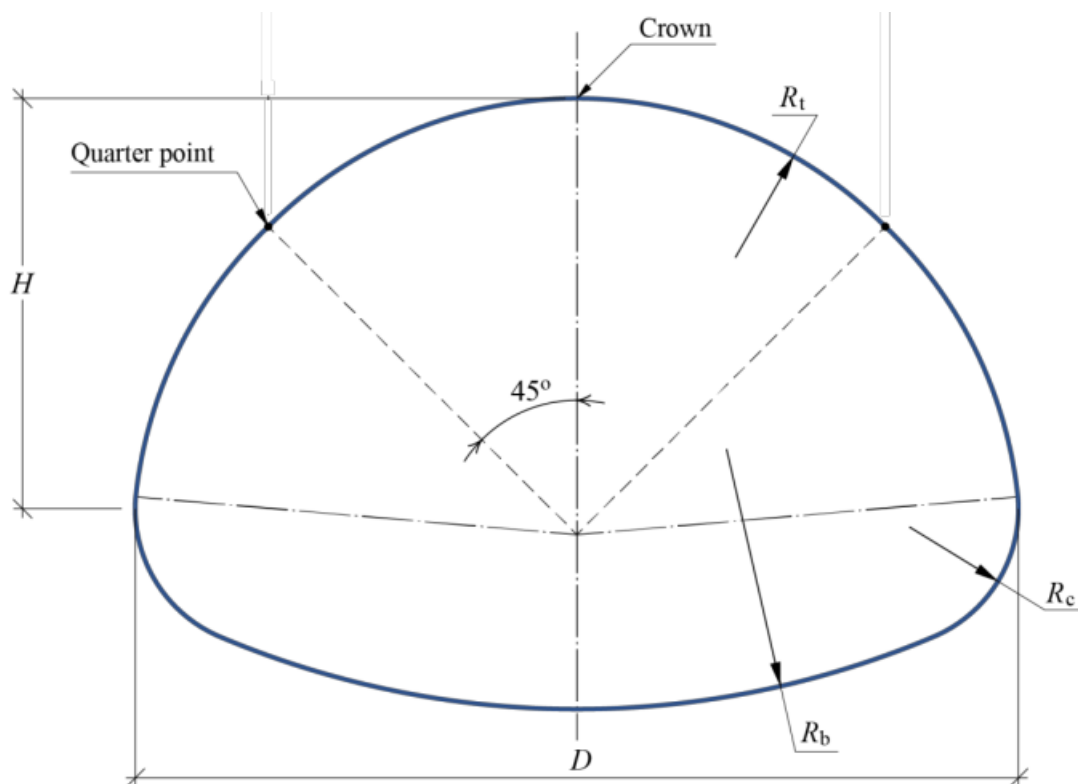

Figure 1.2 *The profile (or cross-section) of the pipe is often divided into a number of parts with different radii. As in Figure 1.1, this figure shows a pipe-arch profile with top radius (R_t), corner radius (R_c), and bottom radius (R_b). The positions of the points normally called the quarter points and the crown are also indicated.*

1.2.2 Calculation and design methods

The forces and moments described in this manual, are calculated using the principles given in the so-called SCI-method, *Duncan (1977)*, *Duncan (1978)*, *Duncan (1979)*, with certain modifications regarding load distribution, soil modulus, depth of cover, and flatter culvert profiles. It is suggested that the load-bearing capacity should be verified following the general principles applied to structures according to the partial safety factor method. The suggested total design method has been verified by comparison with the results of full-scale tests performed and reported by *Pettersson & Persson (1984)*, *Temporal et al (1985)*, *Beben & Manko (2002)*, *Pettersson (2007)*, *Flener (2009)* and *Pettersson & Wadi (2013)*. These tests have included loading to failure, and it has been shown that the safety factor against the development of a plastic hinge is high in the original SCI-method.

The following modifications have been introduced in the SCI-method:

- The design normal force has been reduced when the cover depth is large, following the principles given in *Vaslestad (1990)*.
- The load-bearing capacity has been reduced taking into account second-order theory.
- Methods to calculate the soil modulus has been included based on *Andréasson (1973)*.
- Box culvert profiles are included

The calculation methods used in this manual have been developed by Lars Pettersson and are based on two different theories

- the so-called SCI-method (Soil Culvert Interaction) presented in *Duncan (1978)* and *Duncan (1979)*, and
- the theory described in *Klöppel & Glock (1970)*.

In order to create a theory that incorporates different pipe designs, different soils, different loads etc., the above theories have been complemented with currently used geotechnical analysis methods. The design methods were originally adapted to conform to the manual on steel structures published by the Swedish National Board of Housing, Building and Planning (*Boverket*), first *BSK 99 (1999)* and then *BSK 07 (2007)*.

The calculation models presented by Duncan and by Klöppel & Glock have been compared and calibrated by the results of full-scale tests, among which can be mentioned a pipe-arch profile in Newport, Wales 1984, *Temporal et al (1985)*, a pipe-arch profile in Enköping, Sweden 1987 - 1991, *Pettersson (2007)*, a box culvert over the Gimån river, Sweden 2002, *Beben & Manko (2002)*, an arch profile (railway bridge) over the Skivarpsån river in Sweden 2003 – 2005, *Flener (2003)*, *Flener (2004)*, *Flener (2005)*, and two box culvert profiles in Järpås, Sweden 2005 - 2006, *Flener (2006)* and *Flener (2007)*. The results from the tests at the Skivarpsån Bridge and at the Järpås bridges are also presented in the PhD thesis *Flener (2009)*.

The treatment is suitable for the most commonly occurring systems using relatively thick corrugated steel plates where local buckling does not constitute a problem. The corrugation used shall however be checked with respect to local buckling according to the method described in **Appendix 1**.

Since the method takes into account and is based upon knowledge of the properties of the surrounding soil, it is assumed that the soil closest to the pipe is chosen, backfilled and compacted, and checked in a way such that the soil characteristics described in this manual are achieved and verified.

The conditions for the use of the calculation model have been chosen so that commonly occurring combinations of dimensions and other conditions shall, as far as is possible, be covered by the calculation model. Culverts that fall outside the scope of the stated assumptions shall be treated separately.

Soil steel composite bridges for railways with line speeds exceeding 200 km/h are not covered by this manual.

1.2.3 Accepted culvert profiles

The types of culvert profiles covered by this report are shown in **Figure 1.3**⁷. These types are:

- A.** Circular pipe with constant radius (R).
- B.** Horizontal ellipse. The relationships between the radii shall be such that $R_t / R_s \leq 4$ and $R_b / R_s \leq 4$.
- C.** Vertical ellipse, usually with a ratio between the top or bottom radius (R_t or R_b) and the side radius (R_s) of approx. 0,80. The aspect ratio is normally $1,0 < 2H / D \leq 1,2$.
- D.** Pipe-arch (defined by three radii, viz.: top radius (R_t), bottom radius (R_b) and corner radius (R_c)). The conditions are that $R_t / R_c \leq 5,5$ and that $R_b / R_c \leq 10$. This type is also shown in **Figure 1.2**.
- E.** Pipe-arch (defined by four radii, viz.: top radius (R_t), bottom radius (R_b) and corner radius (R_c) and side radius (R_s)). The conditions are that $R_t / R_c \leq 5,5$, $R_b / R_c \leq 10$ and $R_s / R_t \leq 2,0$.
- F.** Arch with a single radius, often called the top radius ($R = R_t$). This type is usually built on longitudinal concrete footings as shown in the figure.
- G.** Arch consisting of metal plates curved with two or three different radii, viz.: top radius (R_t) side radius (R_s) and corner radius (R_c). The radii for this type of bridge should be chosen so that $R_t / R_s \leq 4$ and so that $1 \leq R_c / R_s \leq 4$.
- H.** Box culvert, where the relationship between the radii is such that $R_t / R_s \leq 12$.

The design checks presented in **Section 5.1**, might affect and reduce the applicable geometrical relative measures.

⁷ The radii shown in **Figure 1.3** are defined to the centre of gravity of the steel sections.

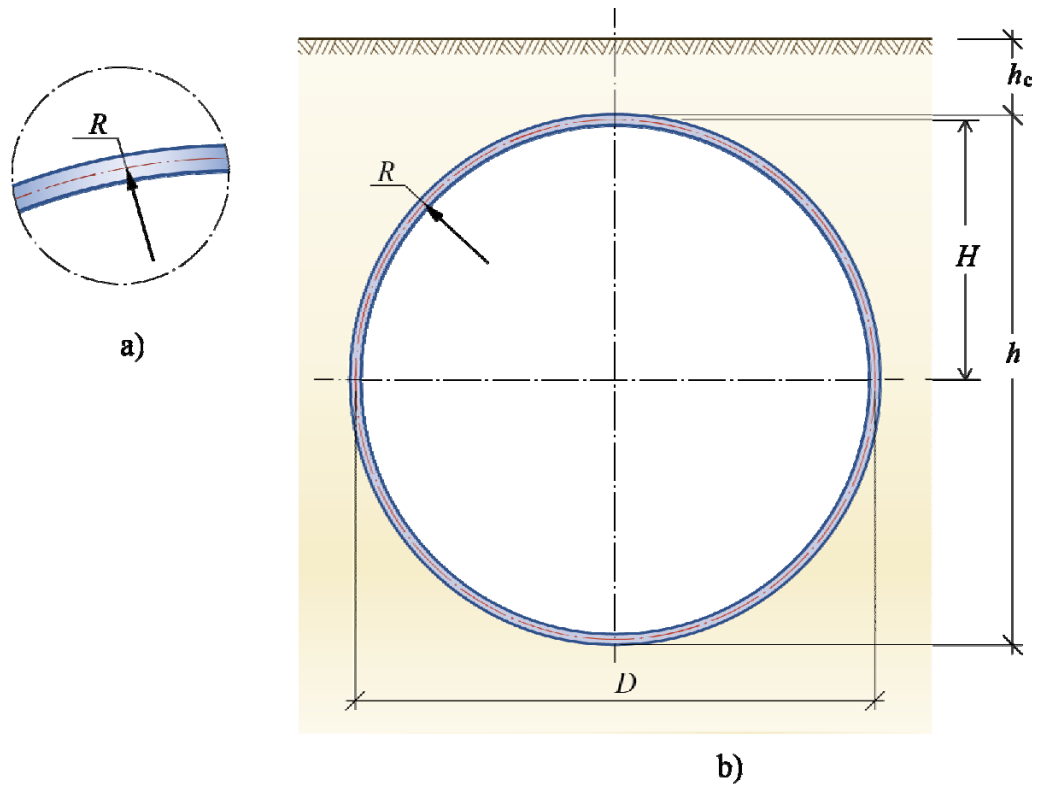

Figure 1.3 A *Circular pipe with constant radius (R)*

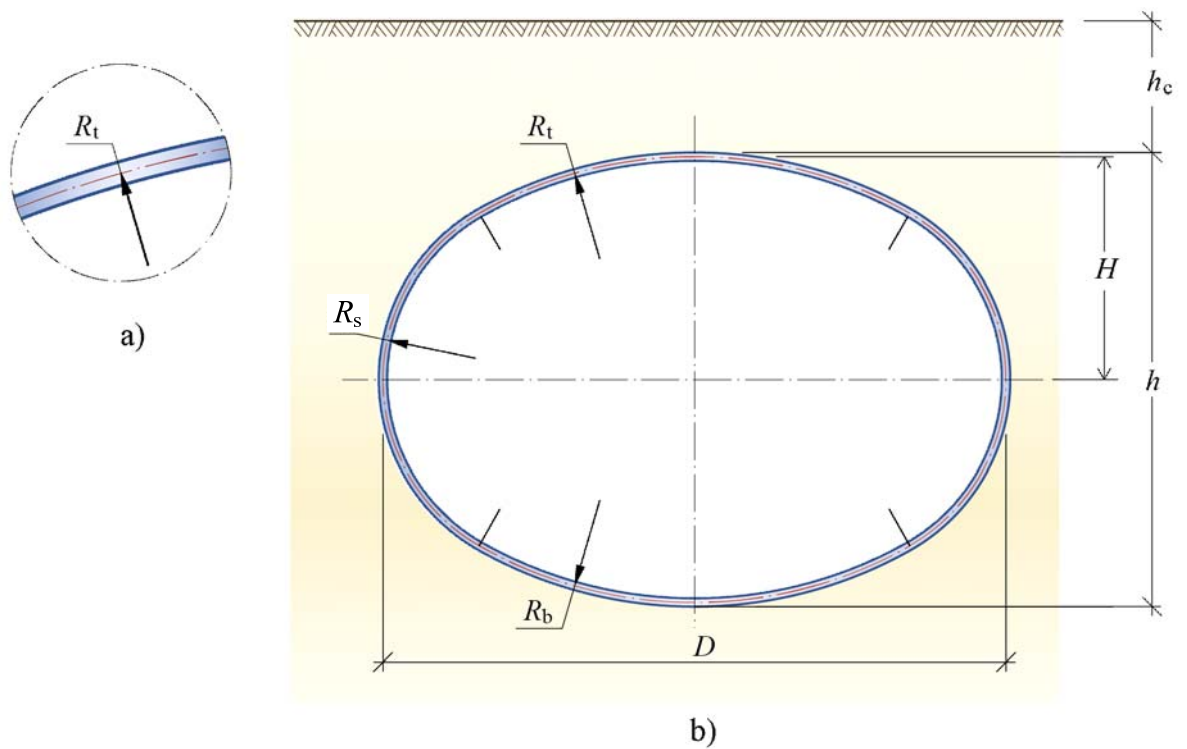

Figure 1.3 B *Horizontal ellipse. The relationships between the radii shall be such that $R_t / R_s \leq 4$ and $R_b / R_s \leq 4$.*

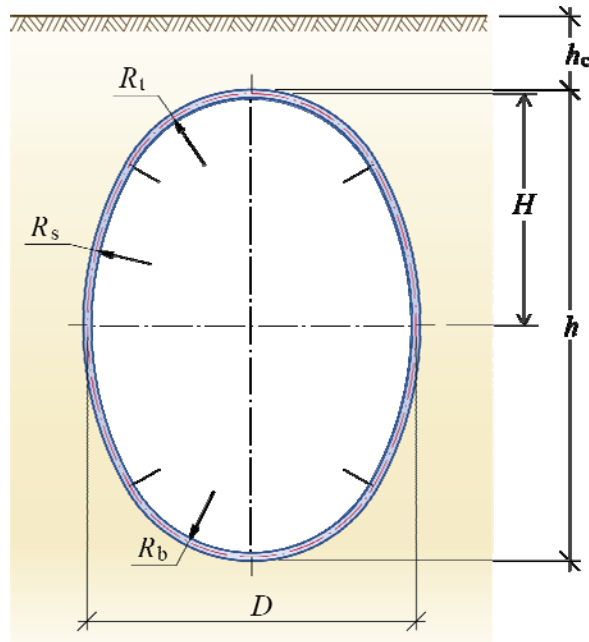

Figure 1.3 C Vertical ellipse, usually with a ratio between the top or bottom radius (R_t or R_b) and the side radius (R_s) of approx. 0,80. The aspect ratio is normally $1,0 < 2H / D \leq 1,2$

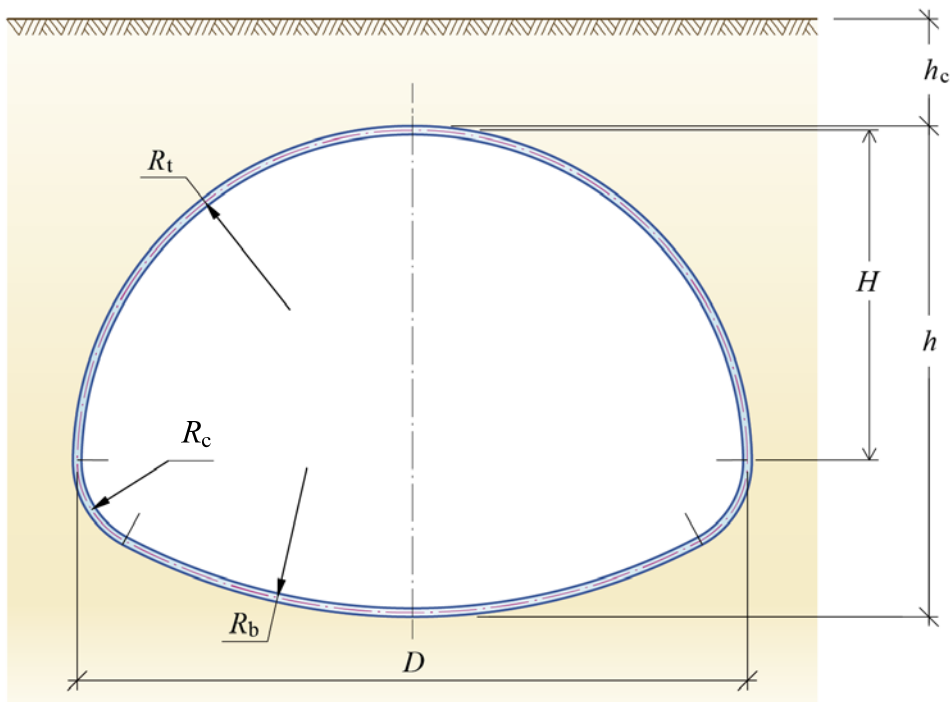

Figure 1.3 D Pipe-arch (defined by three radii, viz.: top radius (R_t), bottom radius (R_b) and corner radius (R_c)). The conditions are that $R_t / R_c \leq 5,5$ and that $R_b / R_c \leq 10$.

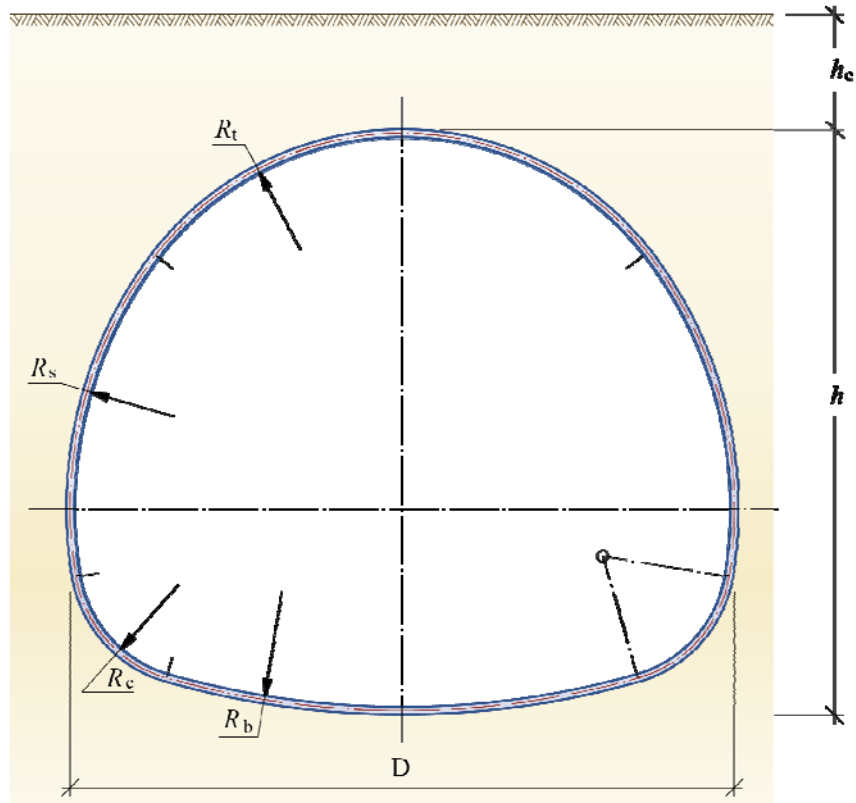

Figure 1.3 E Pipe-arch (defined by four radii, viz.: top radius (R_t), bottom radius (R_b) and corner radius (R_c) and side radius (R_s)). The conditions are that $R_t / R_c \leq 5,5$, $R_b / R_c \leq 10$ and $R_s / R_t \leq 2,0$.

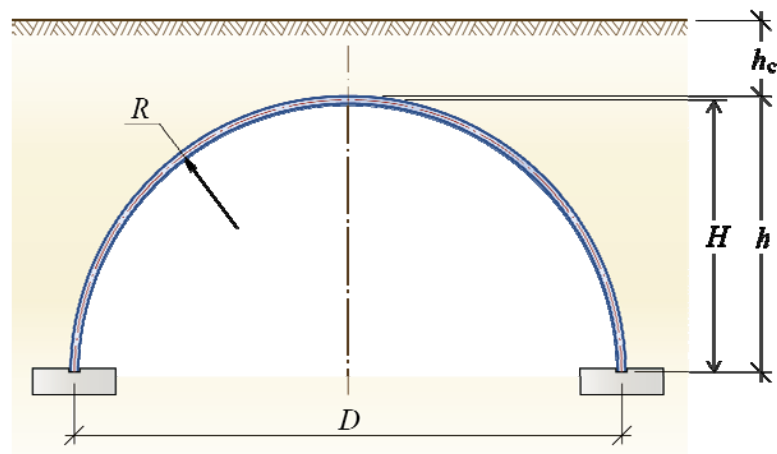

Figure 1.3 F Arch with a single radius, often called the top radius ($R = R_t$). This type is usually built on longitudinal concrete footings as shown in the figure

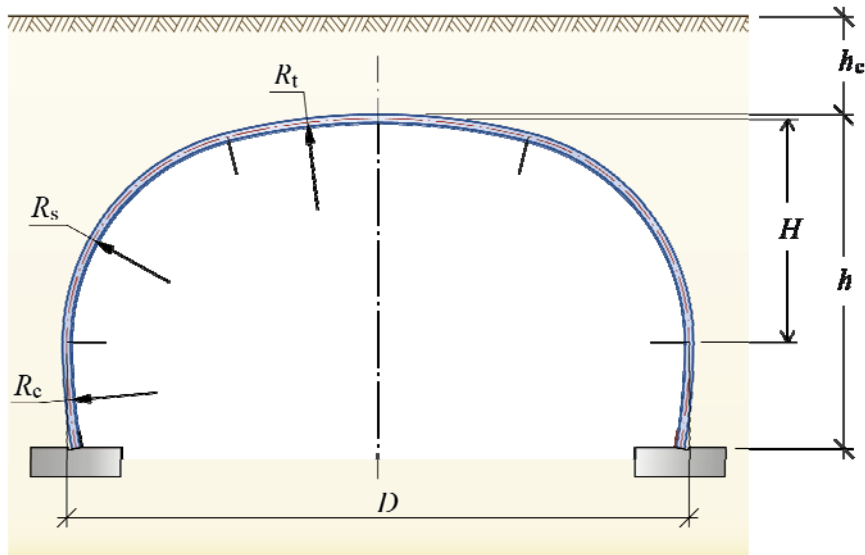

Figure 1.3 G Arch consisting of metal plates curved with two or three different radii, viz.: top radius (R_t) side radius (R_s) and corner radius (R_c). The radii for this type of bridge should be chosen so that $R_t / R_s \leq 4$ and so that $1 \leq R_c / R_s \leq 4$.

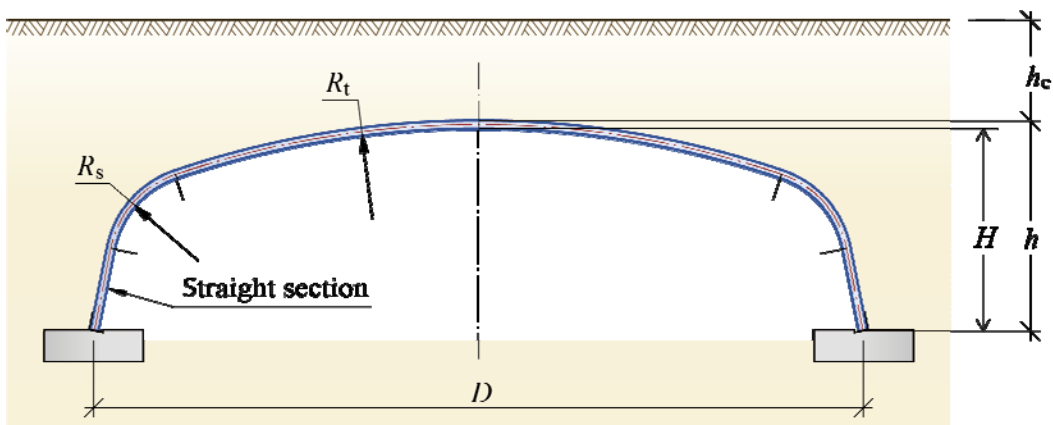

Figure 1.3 H Box culvert, where the relationship between the radii is such that $R_t / R_s \leq 12$.

This manual is applicable to culverts⁸ where $h_c \geq 0,5$ m. Although, in principle, the manual makes it possible to design culverts with large spans (large values of D), the availability of appropriate metal plates, soil materials etc. sets a natural limit for what is possible.

Other types of profiles than those listed above may occur. If a culvert having a type of profile that deviates from the types shown above is to be analysed and designed, special investigations are required.

As mentioned above, a culvert consists of two main parts: the pipe itself and the surrounding soil. Correctly designed, the interaction between these two elements gives the culvert a large

⁸ According to the Swedish Transport Administration, the limit for what is considered to be a bridge is $D > 2,0$ m but this manual is in principle also valid for smaller structures.

load-bearing capacity even with a relatively small cover depth. The influence of the traffic load on the pipe is, however, largely dependent on the depth of the cover.

1.2.4 Soil material requirements

As indicated in **Section 1.1**, the calculation principle in this manual is based upon the effective interaction between the pipe and the soil. It therefore assumes that the structural backfill, i.e. the soil closely surrounding the pipe, has controlled and quantifiable properties. It assumes that the volumes of soil within the areas ①, ②, ③ and ④, as shown in **Figure 1.4** consist of engineered soil masses. For the soil outside these areas i.e. area ⑤, other fill materials can be accepted as far as the function of the culvert is concerned. However, other demands may be applicable for these masses. Examples of such demands may be:

- the soil should have sufficient load-bearing capacity to support possible traffic loads and
- the soil should not have such properties that there is a risk of frost damage to the road or railway lying above the soil or to the structure itself.

The requirements with regard to properties and dimensions, see **Figure 1.4**, which are necessary for this manual to be valid, are:

1. Soil volume ①. $a_2 > 0,3m$, $a_1 \geq 0,2D$. The strength and deformation properties of the soil are defined and measured at a distance larger than 0,5 m from the wall of the pipe. For this material the density is ρ_1 kN/m³. Other geotechnical parameters are given in **Appendix 2**.
2. Soil volume ②. $a_3 = \min (D/2 ; 3,0m)$, $a_4 \geq 0m$. The properties of the soil shall be the same as for ①. It may be necessary to increase the dimensions a_1 and a_2 when considering protection against frost damage etc. The density of this material is denoted ρ_{surr} . As for soil volume ① the strength and deformation properties of the soil are defined and measured at a distance larger than 0,5 m from the wall of the pipe.
3. Soil volume ③. The quality of this soil should be of at least the same quality as for soil volume ②. Special requirements may apply if the soil is carrying a road or railway.
4. Soil volume ④. A layer of at least 0,3 m base course⁹ material is required for roads. For calculation purposes, the density of the material, ρ_{cover} , within the height h_c , is the mean value of the densities of the materials within regions ②, ③ and ④.
5. Soil volume ⑤. The material property requirements and the slope 1:n with respect to the characteristics of the soil, are not affected by the dimensions of the culvert.

⁹ Typical backfill materials used for backfilling of bridges (including soil steel composite bridges) in Sweden ("crushed rock" and "sub base material", are described in this handbook (see also *TK Geo 11*). In addition, "base course material" is also allowed for backfilling against SSCB in Sweden). Other materials can be used and the applicable material can be compared with these materials according to the methods presented in **Appendix 2**.

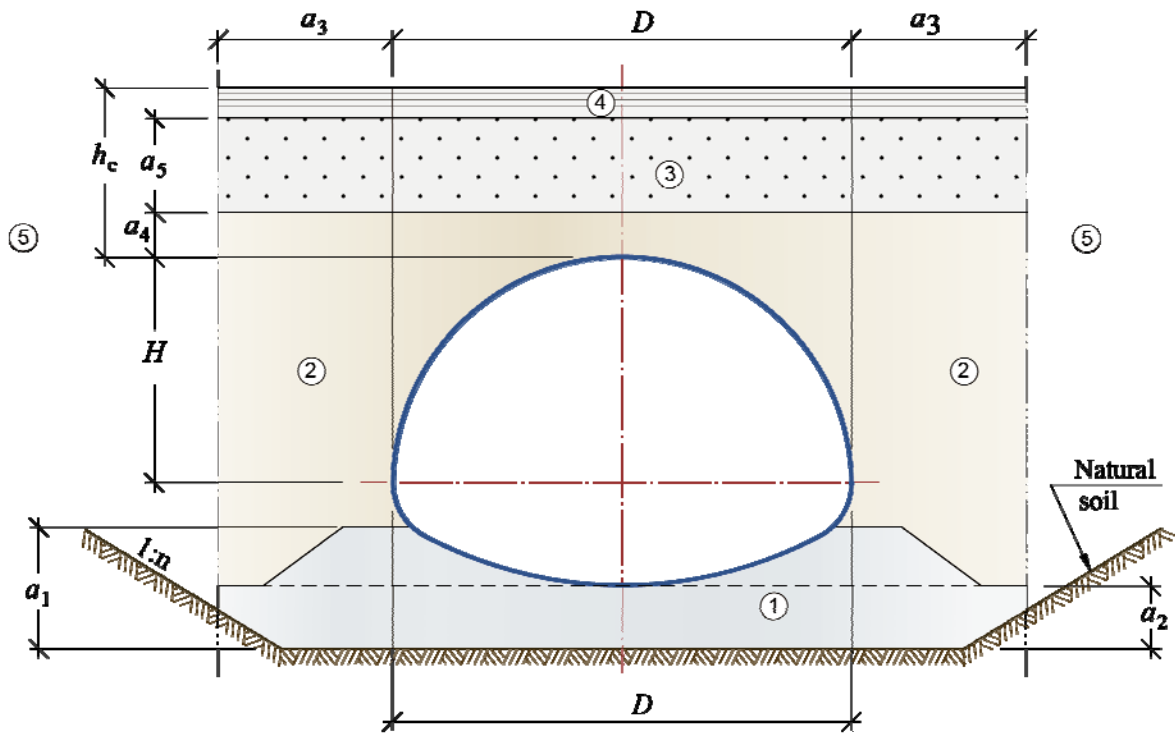

Figure 1.4 *The analysis and design method used in this manual require that the volumes of soil closest to the pipe ①, ②, ③ and ④ have tested and technically quantifiable properties. For these soil volumes, as for the soil volume ⑤, there are further requirements which are not directly related to the design of the pipe. For these requirements, other specifications should be referred to.*

1.2.5 Minimum distance between adjacent pipes

The methods proposed for the design assume that the minimum distance, a , see **Figure 1.5**, between two parallel culverts for culverts of types **A, B, C, D** or **E** should be calculated using the following formula

$$\begin{aligned} D \leq 10 ; a &\geq a_6 \\ 10 < D ; a &= D/10 \end{aligned} \tag{1.a}$$

where

$a_6 = 1,0\text{m}$ is the minimum distance for culverts of types **A, B, C, D** or **E**.

For culverts of types **F, G** or **H**, the following formula shall be used

$$\begin{aligned} D \leq 6 ; a &\geq a_7 \\ 6 < D ; a &= D/10 \end{aligned} \tag{1.b}$$

where

$a_7 = 0,6\text{m}$ is the minimum distance for culverts of types **F**, **G** or **H**, if the adjacent steel structures are founded on a common slab structure, see **Figure 1.6**.

The minimum distance between parallel pipes may also be limited by the size of the compaction machine used for the backfilling process.

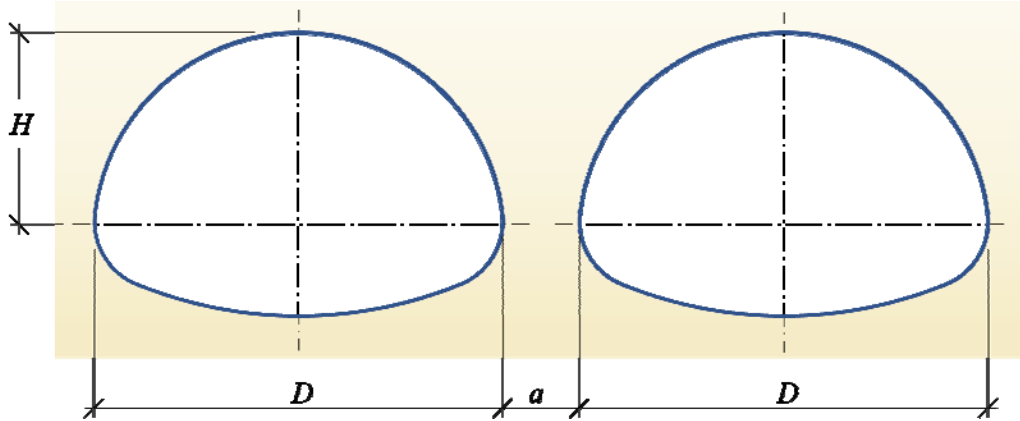

Figure 1.5 *The distance between parallel culverts must be sufficiently large so that the compaction of the soil can be properly achieved and so that the required support is achieved from the soil between the pipes.*

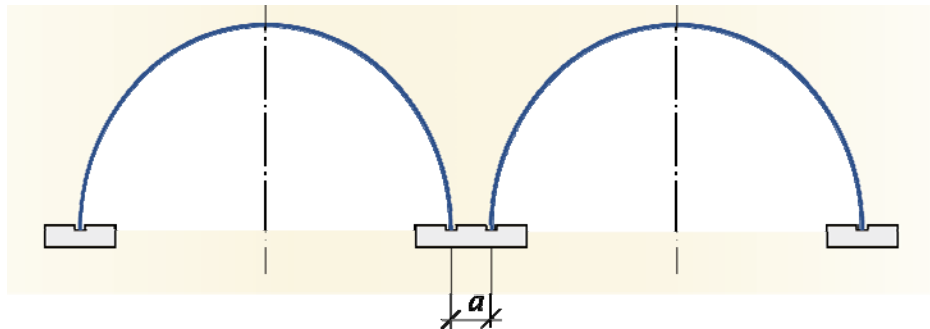

Figure 1.6 *For parallel culverts of types F, G or H, see Figure 1.3, a minimum separation of $a \geq 0,6\text{ m}$ for small spans can be accepted, but the distance must be sufficient so that the compaction of the structural backfill can be properly achieved. Here a is the smallest distance between the profiles.*

If the distance between the profiles is smaller than the values stipulated above the bearing capacity of the structure shall be reduced. It is proposed that the reduction shall influence the design effective tangent modulus of the soil by a factor f_m (reduction factor for minimum distance).

$$f_m = 0,7 + 0,3 \frac{a}{a_{\text{nom}}} \leq 1,0 \quad (1.c)$$

where a is the distance at hand and a_{nom} is the nominal minimum value according to Eqs. (1.a) or (1.b).

1.2.6 Miscellaneous information

Culverts designed in accordance with this manual can, in principle, be used both in those cases where culverts are used under railways or roads and in cases where the culvert is used as a tunnel for a railway or road. In the latter case, there are extra demands with regard to free space around the track, space for signals, cables and overhead cables etc. In addition, the risk of ground settlement must be taken into account.

The lateral and longitudinal slopes of the road profile above the culvert must be checked. A perpendicular slope means that the depth of the cover may be less in places other than the profile plane. Because the relative influence of the traffic load increases considerably for even small changes in cover depth, allowance must be made for this.

As regards the longitudinal slope of the road, the calculation model may be used only for slopes which do not exceed 10 %.

Arches of steel culverts are usually formed using concrete foundations, but the foundations can also be made of steel.

The ends of culverts shall be designed so that an effective compaction of the surrounding structural backfill can be achieved and so that the soil surrounding the ends is not liable to be eroded. It is assumed that the structure is designed so that the soil characteristics specified in **Section 1.2.4** are achieved throughout the entire length of the culvert that is subject to traffic loads and that the soil is not eroded throughout the entire life of the culvert.

The orientation in the horizontal plane of a road or railway above the culvert does not affect the load-bearing capacity of the culvert. This means e.g. that the culvert can be oriented parallel beneath the road, which may be necessary when building protective culverts for electrical cables, or for water and sewer pipes. In the design, consideration must however be given to the distribution of the traffic load, see **Appendix 4**.

2. Design and construction of culverts

2.1 General

Since an efficient interaction between the soil and the structure is crucial for the load-bearing capacity of the culvert, the entire structure, including the structural backfill, must be designed and built with the same care as a structure built entirely of steel or concrete.

In addition to acting as a bridge, a culvert may often form part of a road or an embankment. This means that the requirements which apply for these structures must also be met by the part that forms the culvert.

2.1.1 Durability and lifetime

In this manual the design model presupposes that the thickness of the culvert wall, whether this is made of steel or of some other material, remains intact throughout its lifetime. According to general principles, this requirement can be met using three principles:

- The pipe is given an extra thickness to provide for possible corrosion or abrasion, so that the effective structural thickness throughout its lifetime is at least that required according to these design rules.
- The pipe is given corrosion protection in the form of galvanising and/or protective painting so that its thickness throughout its lifetime is at least that required according to these design rules.
- The culvert pipe is inspected, maintained and repaired so that its thickness during its lifetime is at least that required according to these design rules. It is also necessary to check the soil surrounding the pipe to ensure that it remains intact and can fulfil its purpose to provide the required support to the pipe throughout the culvert's lifetime.

Detailed regulations for ensuring durability and service life are in Sweden issued in *TRVR Bro 11 (2011)*. In other countries it is presumed that the relevant authority issues regulations.

2.2 Preliminary design of culverts

Culverts should be planned with the same degree of care as other structures and according to the rules and regulations laid down by the authority in question.

2.2.1 Geotechnical investigations

Geotechnical investigations shall be carried out according to the principles that apply for the road, track or their equivalent in which the structure is to be included. Often the part of the track or road surrounding the culvert is heavier than the part containing the culvert. Therefore, the requirements regarding settlements etc. are no more stringent than those for the road or track in general. Culverts of steel are flexible structures and small settlement differences (angular changes of less than 1:50 in the pipes longitudinal direction) can normally be accepted, at least as far as the culvert's load-bearing capacity is concerned.

In addition to the geotechnical investigations required for the track or road in general, the structural backfill and the bedding material must be checked to ensure their suitability for achieving the necessary density, degree of compaction and stiffness. In order for the more exact method to be applicable, see **Appendix 2**, it is assumed that the properties of the soil are checked with regard to:

- a) particle size grading,
- b) maximum dry density, and
- c) achieved dry density.

2.2.2 Documentation

Documentation must be provided in accordance with the regulations which apply for other structures and in accordance with the regulations of the procuring authority.

2.3 Construction methods

In many cases the erection and final construction of soil-steel composite bridges is a fast and cost-effective process. **Figure 2.1** shows an example of the finalized erection of the steel part of the bridge just before starting the backfilling process.



Figure 2.1 *The finalized erection of the steel part of a SuperCor horizontal ellipse bridge, see Figure 1.3 B, just before starting the backfilling process.*

In contrast to many other types of bridges where the soil surrounding e.g. abutments solely contributes in the form of a load, the load-bearing capacity of a culvert relies on an effective interaction between the pipe and the soil. Careful workmanship, where excavation, backfilling and compaction conform to the stated requirements, is critical for a successful result.

The principles for the construction are indicated in this manual and in the regulations issued by the relevant national or local authorities.

2.4 Aesthetical design of soil steel composite bridges

The vault form of the most used culverts is of many considered to be aesthetical pleasing. By completing the steel structure by well designed details, nice looking bridges can be achieved. **Figure 2.2** shows an example of a nice design of an overpass for animals and **Figure 2.3** shows a small bridge, where the glacis is covered by stones in concrete.



Figure 2.2 *By completing the steel structure with well-designed details, nice looking bridges can be achieved. This bridge is one of the largest SSCB in Europe having a 20 m span.*



Figure 2.3 *A nicely worked out glacis covering the slopes of a pipe-arch bridge.*

3. Principles for analysis

3.1 General conditions

Culverts of steel and steel arches shall be designed according to the *Eurocodes* together with the complementary conditions indicated in this section and in **Chapters 4 and 5**. The methods used in this manual could, using the Eurocode vocabulary, be considered following the design situations STR and FAT. For culverts made from a material other than steel, the reader is referred to those standards that are applicable to the respective materials. The concrete footings of an arch shall be checked in accordance with the relevant concrete standard.

3.2 General calculation principles

When designing a culvert, it is assumed that the culvert has a uniform section over a long distance in the pipe's longitudinal direction. Further, the calculation model assumes that it is possible to consider a strip with a length of one metre subjected to loading forces acting perpendicularly to the axis of the pipe. If the culvert changes section in any part, then each section must be checked. This also applies if the depth of cover or backfilling material varies along the culvert.

When subjected to a traffic load, the upper part of the culvert profile (roughly speaking, the region between the quarter-points, see **Figure 1.2**) can be considered separately. This “top-arch” has elastic supports whose characteristics are defined by the amount of lateral support that can be provided by the soil surrounding the pipe. The arch is also continuously elastically supported with the aid of the mass of soil lying above the arch. The most important calculation is directed to the treatment of this top-arch, as it is mainly this area that is affected by the traffic load.

In the upper part of the pipe profile (the top arch), the normal force can from a calculation point of view, be considered constant, while the bending moment due to the traffic load is such that the negative value is roughly half the positive value.

Culverts where the surrounding backfill consists entirely, or in part, of light-weight filling material are not directly covered by this manual. In those cases where such culverts need to be designed it is first necessary to establish the characteristics of the surrounding fill, in terms of its tangent modulus¹⁰ and density, in order to determine a stiffness parameter (see **Section 4.5**). When this has been done, in accordance with the guidelines given in **Section 4.5.1** and the principles given in **Appendix 2**, the calculation model can also be applied to this type of culvert.

¹⁰ *Duncan (1979)* uses the term “secant modulus”. In normal usage, however, this is referred to as the “tangent modulus” and this term is therefore used throughout this manual.

3.3 Limitations

This manual deals with culverts having stiffness parameters within the range given by $100 \leq \lambda_f \leq 50\,000$ (see **Section 4.5**).

No special requirement need be stated with respect to cover depth, but h_c shall always be at least 0,5 m for the calculation model in this manual to be considered valid¹¹. Those parts of the road or railway superstructure which are definitely present for the load case studied are to be included in h_c . If, for example, the superstructure is to be replaced, a check must be made to ensure that the reduced depth of cover can support the temporary loads which may arise during the construction work. In the case of a culvert under a railway, the depth of cover should therefore be at least 1,00 m (= 0,50 m + a ballast thickness of 0,50 m) in order to ensure that the required cover depth is retained during e.g. ballast maintenance and change.

Limitations with regard to radii etc. are indicated in **Section 1.2.3**.

In this manual, the values given for moments and forces assume that no special measures are adopted during backfilling that will influence the pattern of forces. If such measures are adopted, the analysis of the culvert must take into consideration the changed conditions. An example of a method which is used to reduce the deformations during back filling and which may influence the moment distribution is to add soil on the pipe's crown.

3.4 Characteristics of the structural backfill

The surrounding soil material is assumed to be compacted friction material, for further information see **Sections 1.2.4** and **Appendix 2**.

It is necessary to characterise the properties of the soil at the sides and above the culvert as follows. Information relating to the soil material in the different backfill regions, as shown in **Figure 1.4**, is necessary in order to calculate the capacity of the pipe walls. This means that information is required which makes it possible to calculate the soil modulus, as indicated in **Appendix 2**. In addition, the following clarifications are necessary:

- Within the height of cover (regions ② (part of), ③ and ④) the density is given by ρ_{cover} . If different soil materials (including any road or railway track superstructure) are used in this region, a weighted average density is used. It should be noted that an asphalt surfacing does not spread the load or improve the soil material properties in any other way.
- Within the region with a height equal to $(h_c + H/2)$, the density is denoted $\rho_{h_c+H/2}$. If different soil materials are used in this region, a weighted average density is used.

In the case of culverts where light clinker or some other lightweight material is used as backfill, special investigations shall be carried out to establish the characteristics and thus the stiffness parameter, λ_f , of the material, in accordance with the principles given in **Appendix 2**.

¹¹ For existing structures with h_c less than 0,5, **Appendix 7** gives methodologies for cases with very low height of cover.

3.5 Live loads

The loads are assumed to arise from different types of traffic loads e.g. loads according to *Eurocode 1991-2*, *EKS 9*, *TRVFS 2011:12*, or their equivalent.

The only live load considered in the design of SSCB is traffic loads. The effects of the traffic loads are discussed in **Section 4.5.3**, **Appendix 4** and **Appendix 6**.

3.5.1 Dynamic amplification factor

According to basic principles, the dynamic effect should decrease as the amount of soil involved increases, as a result of frictional losses and load spreading within the soil material. Tests described by *Smagina (2001)* showed, however, that the depth of the cover had only a slight effect on the dynamic amplification. For culverts with cover depths greater than 2 m, a conservative reduction factor, r_d , is therefore applied to *reduce the dynamic amplification*.

The dynamic amplification can be reduced as indicated in Eq. (3.a), provided the cover depth is large:

$$\left. \begin{aligned} h_{c,red} < 2\text{ m} &\Rightarrow r_d = 1,0 \\ 2\text{ m} < h_{c,red} < 6\text{ m} &\Rightarrow r_d = 1,10 - 0,05h_{c,red} \\ 6\text{ m} < h_{c,red} &\Rightarrow r_d = 0,8 \end{aligned} \right\} \quad (3.a)$$

Eq. (3.a) is illustrated in **Figure 3.1**

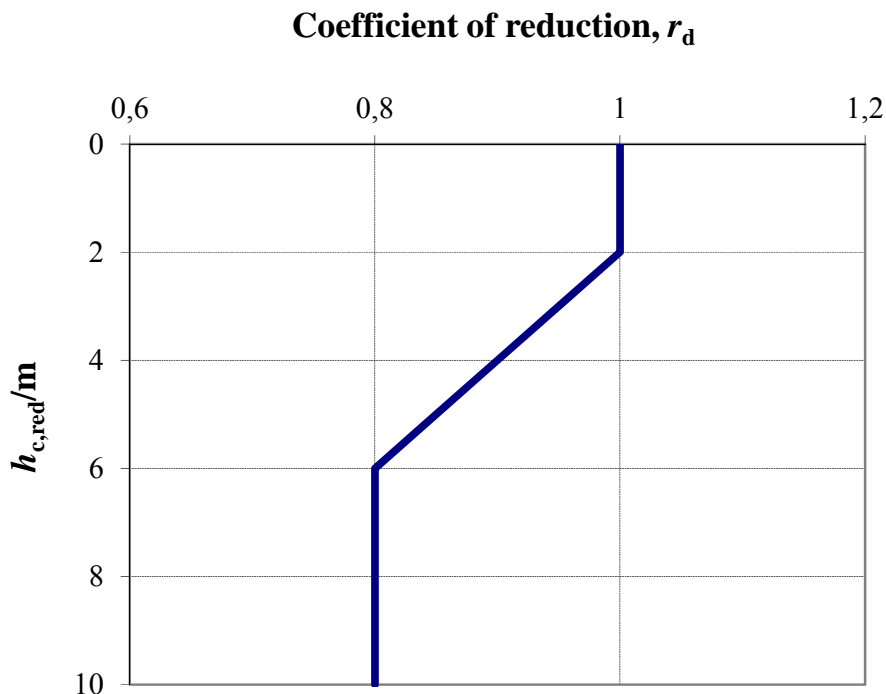

Figure 3.1 Reduction of the traffic load, including dynamic effect, with increasing depth of cover as a result of a reduction in the dynamic effects.

3.6 Cross-sectional properties

A geometrical description is given in **Appendix 1**, together with the area, section modulus and moment of inertia of several common types of corrugated sections.

4. Load effects

4.1 General

The forces and moments that arise as a result of loads on the pipe are calculated using the equations below. The so-called SCI method, which is based on FEM calculations, is used as the starting point for these calculations. The method makes it possible to estimate the section forces arising both from soil loads (both during the back-filling process and in the permanent situation) and from live traffic loads.

4.2 Risk for local failure at very small cover depths and a minimum height of cover

In order to minimise the risk of local failure under a concentrated load, a cover depth of at least 0,5m is required in the calculation model. In those cases where large wheel pressures can occur, it is further required that the upper part of this layer shall consist of an appropriate road or railway superstructure, for further details see **Section 1.2.4**.

4.3 Effective height of cover

During the installation of a culvert the crown rises during the back-filling process because of the pressure of the soil acting against the sides of the pipe. This results in a reduced depth of cover for any given positive height between the bottom of the pipe and the road surface.

The reduced cover depth to be used in the calculations is therefore

$$h_{c,\text{red}} = h_c - \delta_{\text{crown}} \quad (4.a)$$

The increase in height of the pipe during the back-filling operation may be assumed to be approximately

$$\delta_{\text{crown}} = 0,015 \cdot D \quad (4.b)$$

Alternatively, a more rigorous calculation may be undertaken as indicated in **Appendix 3**.

4.4 Normal forces

The calculation model assumes that the maximum normal forces and moments are calculated. The load-bearing capacity is checked with respect to both the normal force and to the combination of normal force and moment using an interaction formula.

4.4.1 Sectional forces due to the surrounding soil

The normal force, N/m, caused by the load due to the backfill soil in its permanent position (characteristic value) is determined as

$$N_{\text{soil,k}} = 0,2 \frac{H}{D} \rho_{\text{surr}} D^2 + S_{\text{ar}} \left(0,9 \frac{h_{\text{c,red}}}{D} - 0,5 \frac{h_{\text{c,red}}}{D} \frac{H}{D} \right) \rho_{\text{cover}} D^2 \quad (4.c)$$

where ρ_{surr} and ρ_{cover} are defined in **Section 1.2.4**.

When applying this design method, the density above the ground-water level shall be used regardless of the actual position of the ground-water level.

Equation (4.c) is shown graphically in **Figure 4.1** with two different parameter combinations for the case when $\rho = \rho_{\text{surr}} = \rho_{\text{cover}}$ and the arching coefficient $S_{\text{ar}} = 1,0$.

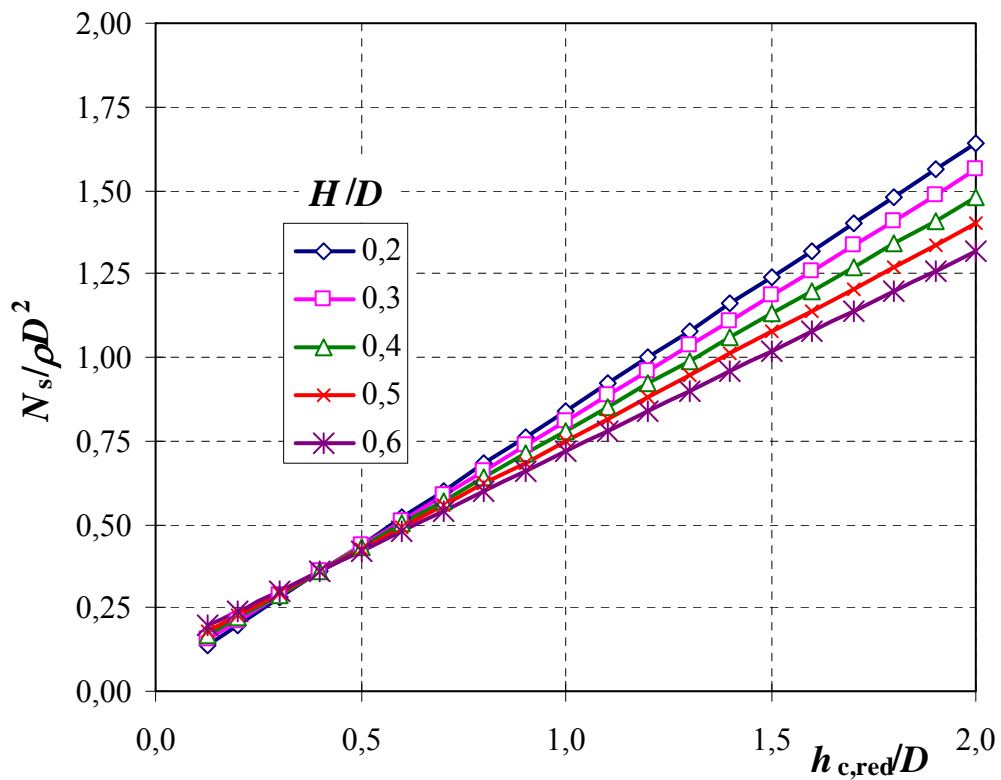

Figure 4.1.a Relationship between the normal force due to the dead load of the cover and surrounding soil, the cover-to-depth ratio $h_{\text{c,red}}/D$ and the rise-to-span ratio H/D for the case when the weight density, ρ , of the soil is the same both above and below the crown.

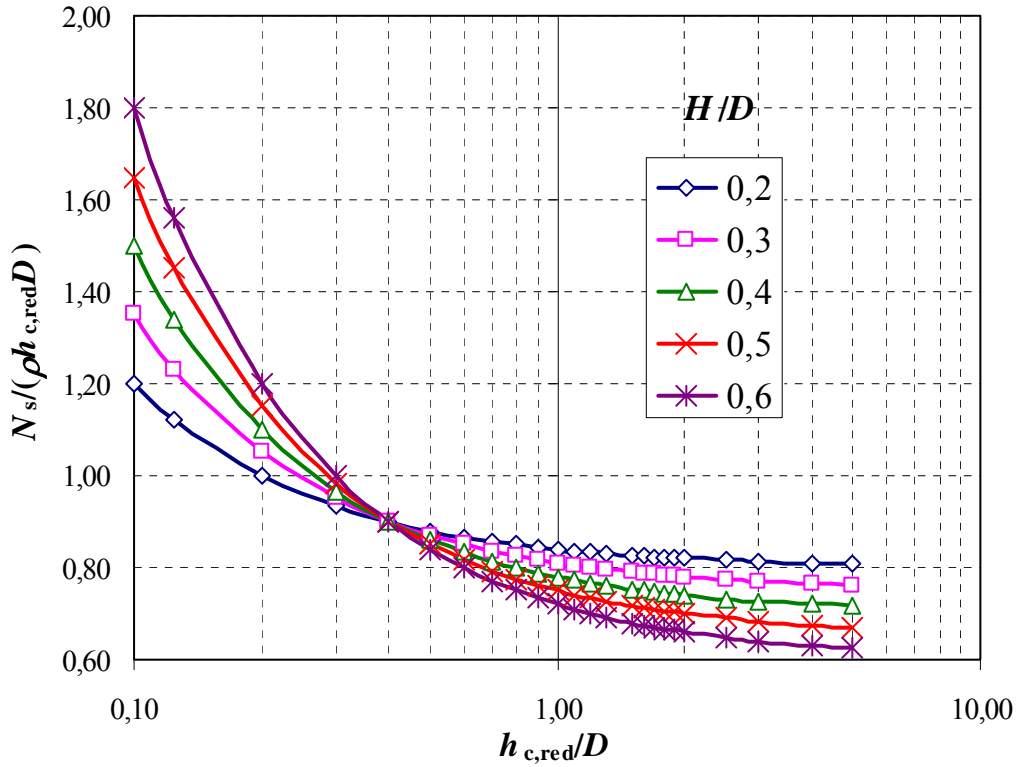

Figure 4.1.b Relationship between the normal force due to the dead load of the cover and surrounding soil, the cover-to-depth ratio $h_{c,red}/D$ and the rise-to-span ratio H/D for the case when the weight density, ρ , of the soil is the same both above and below the crown.

The coefficient S_{ar} takes into account the effect of arching of the soil above the culvert which occurs with large cover depths. If the culvert is placed in an excavation in natural soil or rock, this effect may be calculated as follows where $\varphi_{cover,d}$ is the design angle of internal friction for the cover material,

$$\tan \varphi_{cover,d} = \frac{\tan \varphi_{cover,k}}{\gamma_{M,soil}} \quad (4.d)$$

In Eq. (4.d), the value of $\gamma_{M,soil}$ for internal friction is normally 1,3. The angle of internal friction to be used in Eq. (4.d) refers to the soil above the culvert.

$$S_v = \frac{0,8 \tan \varphi_{cover,d}}{\left(\sqrt{1 + \tan^2 \varphi_{cover,d}} + 0,45 \tan \varphi_{cover,d} \right)^2} \quad (4.e)$$

$$\kappa_1 = 2S_v \frac{h_{c,red}}{D} \quad (4.f)$$

$$S_{ar} = \frac{1 - e^{-\kappa_1}}{\kappa_1} \quad (4.g)$$

Figure 4.2, show examples of the value of the arching coefficient S_{ar} .

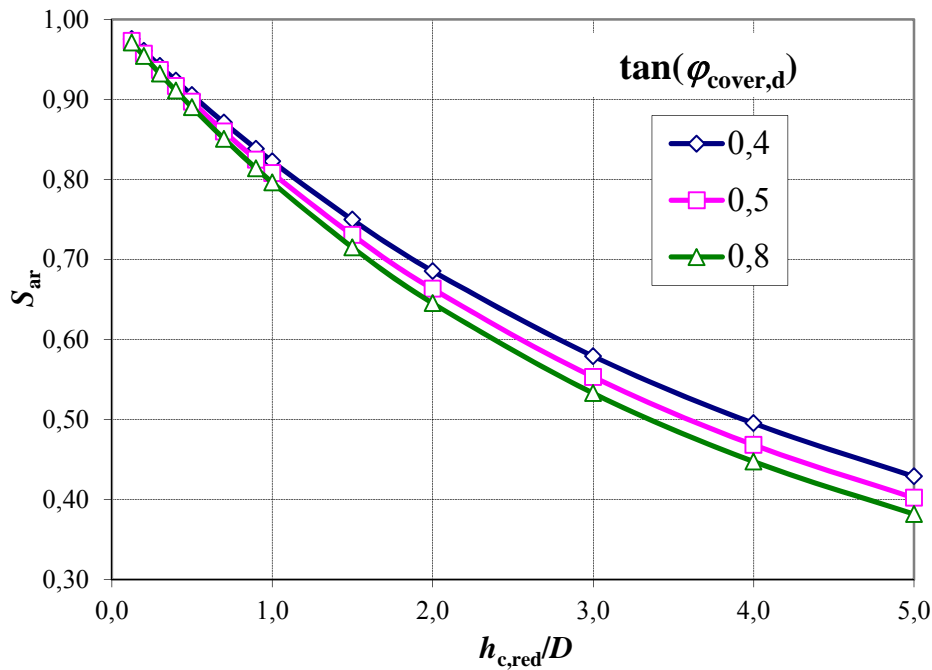

Figure 4.2 The arching coefficient, S_{ar} , versus the relative cover depth ratio, h_c/D , for different angles of internal friction of the material above the pipe.

Table 4.1 shows values of the quantity S_v for backfill soil materials used in Sweden.

Soil material in the cover	$\varphi_{cover,k}$	$\varphi_{cover,d}$	$\tan \varphi_{cover,d}$	S_v
Crushed rock	45°	38°	0,77	0,24
Sub base material	40°	33°	0,65	0,23
Base course material	43°	36°	0,72	0,24

Table 4.1 Calculation of S_v for backfill soil materials used in Sweden.

4.4.2 Evenly distributed traffic loads

Distributed loads give rise to both normal forces and bending moments and the effect is calculated according to the methods shown in the following.

4.4.3 Concentrated traffic loads

Load distribution from concentrated loads (e.g. wheels of vehicles) should be calculated according to Boussinesq's method. The reason why this method is used is that, for example,

the 2:1 method is considered to be too conservative while the distribution 1:1 yields non-conservative values. In addition, the simplified load distribution method yields discontinuities in the vertical pressure from the traffic loads when it is expressed as a function of the depth of cover. Axle and bogie loads are converted to equivalent line loads at the roadway level, p_{traffic} . See **Section 4.4.4**, **Appendix 4** and **Appendix 6**.

4.4.4 Calculation of the equivalent line load, p_{traffic} and the normal force due to traffic

The SCI-method is based on the concept that the actual traffic load is converted, with the aid of the stress distribution in a semi-infinite body according to *Boussinesq (1883)*, to the equivalent line load which yields the same vertical stress at the level of the crown of the pipe as the traffic load itself.

Boussinesq gives the following relationship for the vertical stress at a depth z (vertically beneath the load) caused by a line load p applied to a semi-infinite elastic body:

$$\sigma_v = \frac{2 \cdot p}{\pi \cdot z} \quad (4.h)$$

In the same manner for a point load, the expression:

$$\sigma_v = \frac{3 \cdot P \cdot h_{c,\text{red}}^3}{2\pi \cdot s^5} \quad (4.i)$$

is obtained, where s is the sloping distance between the point load and the calculation point at depth $h_{c,\text{red}}$. Point and line loads are converted to an equivalent line load p_{traffic} . In the absence of a more precise method, equations (4.h) and (4.i) are used so that the vertical stress at the point concerned is calculated according to Boussinesq, and the equivalent line load at the point which is subjected to the greatest vertical stress is thereafter calculated using the equation:

$$p_{\text{traffic}} = \frac{\pi h_{c,\text{red}}}{2} \sigma_v \quad (4.k)$$

Appendix 4 contains examples of the calculation of p_{traffic} for typical axle and bogie loads associated with road traffic. Corresponding examples for railway traffic are presented in **Appendix 6**.

On the basis of this information, the force in the wall of the pipe is calculated as follows.

$$\text{if } h_{c,\text{red}} / D \leq 0,25 ; \quad N_{\text{traffic},k} = p_{\text{traffic},k} + (D/2) \cdot q_k \quad (4.l)$$

$$\text{if } 0,25 < h_{c,\text{red}} / D \leq 0,75 ; N_{\text{traffic},k} = (1,25 - h_{c,\text{red}} / D) \cdot p_{\text{traffic},k} + (D/2) \cdot q_k \quad (4.1'')$$

$$\text{if } 0,75 < h_{c,\text{red}} / D ; N_{\text{traffic},k} = 0,5 p_{\text{traffic},k} + (D/2) \cdot q_k \quad (4.1''')$$

These equations (4.1) are illustrated in **Figure 4.3**, neglecting the effect of the evenly distributed traffic load. The distributed load q_k is the distributed characteristic lane load of the standard at hand.

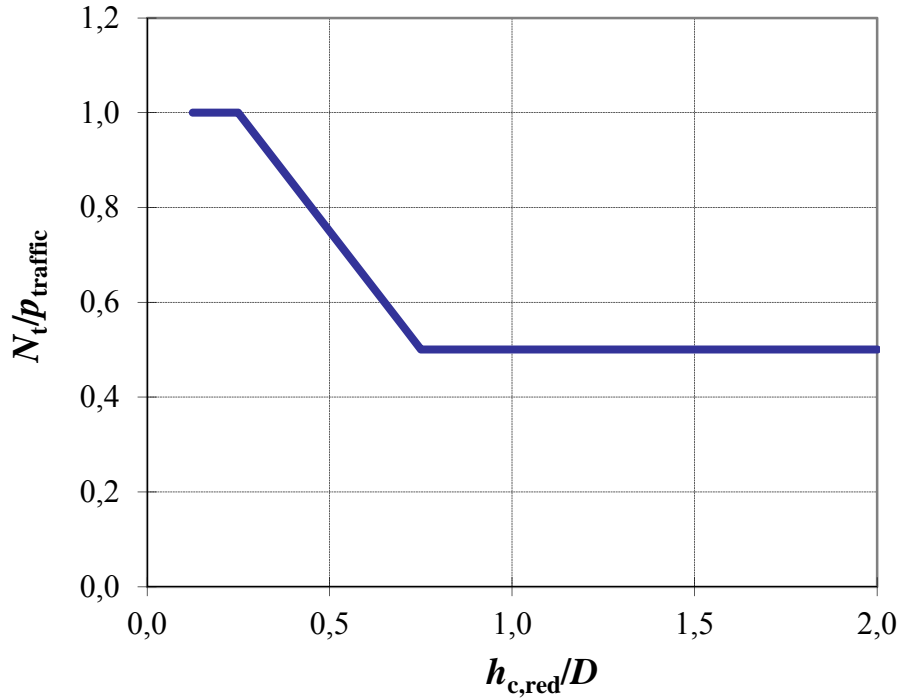

Figure 4.3 The relationship between the normal force and the characteristic equivalent line load $p_{\text{traffic},k}$ as a function of the relative cover depth ratio $h_{c,\text{red}}/D$ when $q = 0$.

4.4.5 Design normal force

The design normal force in the serviceability limit state is given by

$$N_{d,\text{SLS}} = \gamma_{\text{soil},\text{SLS}} \cdot N_{\text{soil},k} + \gamma_{\text{traffic},\text{SLS}} \cdot N_{\text{traffic},k} \cdot \left[\text{if } R_t / R_s > 1,0 ; (R_t / R_s)^{0,25} \text{ else } 1,0 \right] \quad (4.m)$$

and in the ultimate limit state by

$$N_{d,\text{ULS}} = \gamma_d \left\{ \gamma_{\text{soil},\text{ULS}} \cdot N_s + \gamma_{\text{traffic},\text{ULS}} \cdot N_{\text{traffic},k} \right\} \quad (4.n)$$

where γ_d is the partial coefficient for safety class, see *EKS 9* or *TRVFS 2011:12*, and in the fatigue limit state by

$$N_{\text{traffic,d,FAT}} = \gamma_{\text{traffic,FAT}} \cdot N_{\text{traffic,k,FAT}} \cdot \left[\text{if } R_t / R_s > 1, 0 : (R_t / R_s)^{0,25} \text{ else } 1, 0 \right] \quad (4.o)$$

The values of the partial coefficients¹² recommended by the relevant authority are inserted in the above equations.

4.5 Bending moments

4.5.1 General

The bending moment in the wall of the pipe depends on the relationship between the stiffness of the soil and the stiffness of the pipe. This relationship is denoted by λ_f , and is given by:

$$\lambda_f = E_{\text{soil,k}} \cdot D^3 / (EI)_{\text{steel}} / \gamma_{M,\text{soil}} \quad (4.p)$$

where $E_{\text{soil,k}}$ is the characteristic tangent modulus of the soil¹³ $(EI)_{\text{steel}}$ is the bending stiffness of the pipe $E = 200$ GPa and $\gamma_{M,\text{soil}}$ is the partial coefficient for soil stiffness. Recommended value is 1,3. The tangent modulus of the soil material is dependent on the prevailing stress distribution within the soil. Methods of calculating the characteristic tangent modulus are given in **Appendix 2**. In the design of a culvert with different soil materials within a height equal to $(h_c + H)$, a weighted average value of $E_{\text{soil,k}}$ shall be used in the calculation of λ_f . In the simplified model, only knowledge of the degree of compaction is required. This can be determined either according to the Standard Proctor, RP^{std} method or the Modified Proctor, RP^{mod} method. The relationship between the Standard Proctor and the Modified Proctor for friction material is assumed to be $RP^{\text{std}} = RP^{\text{mod}} + 5\%$.

The degree of compaction shall be inserted as a percentage (for information regarding the conditions for the degree of compaction, see **Appendix 2**). In the equation, the stress in the region immediately under the pipe's quarter-point – at the depth $(h_c + H/2)$ – has been used as the starting point for the calculation¹⁴.

When the structural backfill consists of lightweight filling material the material parameters shall be determined through a special investigation.

¹² Observe that earlier Swedish standards use a partial factor for safety class γ_n and that this factor and the partial safety coefficient γ_m for material is in the denominator when deciding the design strength.

¹³ Note 2 to Eq. (4.p): For lightweight filling, a direct comparison is made between the tangent modulus for the actual lightweight fill and for a surrounding fill of frictional material, both having an effective vertical stress corresponding to that prevailing at the pipe's quarter-points. As a starting point for the calculation, the same principles as those used for a friction material in **Appendix 2** should be used. In this case, only a region of $2D/3$ closest to the pipe is of interest. If only a part of this region consists of lightweight fill, a direct proportioning of the share of lightweight fill (within $2D/3$) shall be used.

¹⁴ Note 1 to Eq. (4.p): When the dimensionless constant λ_f is to be calculated, the following units are to be used. For the tangent modulus: MPa, for the steel's modulus of elasticity: MPa and for the moment of inertia: m^4/m . The characteristic value of the steel's modulus of elasticity shall be used.

The moments which arise in a culvert are built up in three different stages:

1. Firstly, a moment distribution is created by the lateral pressure which arises before any filling material is placed on top of the culvert, as shown in **Figure 4.4 a)**
2. When the culvert is later covered, i.e. material is packed above the level of the crown, the moment will change, as shown in **Figure 4.4 b)** and **Figure 4.5**.
3. Traffic and other loads will subsequently give rise to other moment distributions, as indicated in **Figure 4.8 a)** and **Figure 4.8 b)**.

This process and the equations describing it are given in **Sections 4.5.2** and **4.5.3**.

4.5.2 Bending moments due to the surrounding soil

The bending moment caused by the soil load can, for both the serviceability limit state and the ultimate limit state, be expressed by Eq. (4.q).

The equation is based on the observation that when the backfill is compacted around the flexible structure, the structure is pressed inwards at the sides and a negative moment is created at the crown. This reaches a maximum when the level of filling reaches the level of the crown, and this is represented by the first term on the right-hand side of Eq. (4.q). When the work of filling is continued above the level of the crown, the structure is pressed down and the negative moment is reduced. These processes are shown schematically in **Figure 4.4**. If the height of the cover is large, as is shown in **Figure 4.5**, the moment in the crown can change sign and become a positive moment.

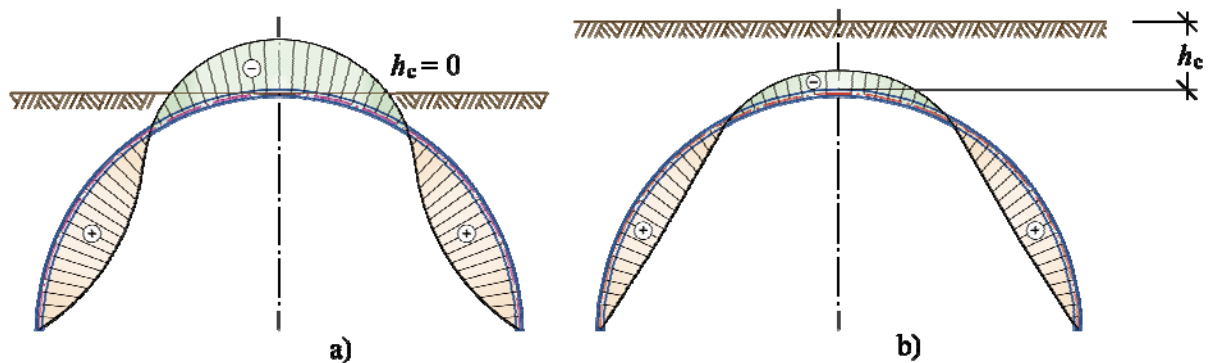

Figure 4.4 A schematic representation of the distribution of moments in a culvert during backfilling. a) the moment distribution when the backfilling has reached the level of the crown and when the negative moment has reached its maximum value. b) the absolute value of the moment in the crown decreases as the cover over the crown filling increases.

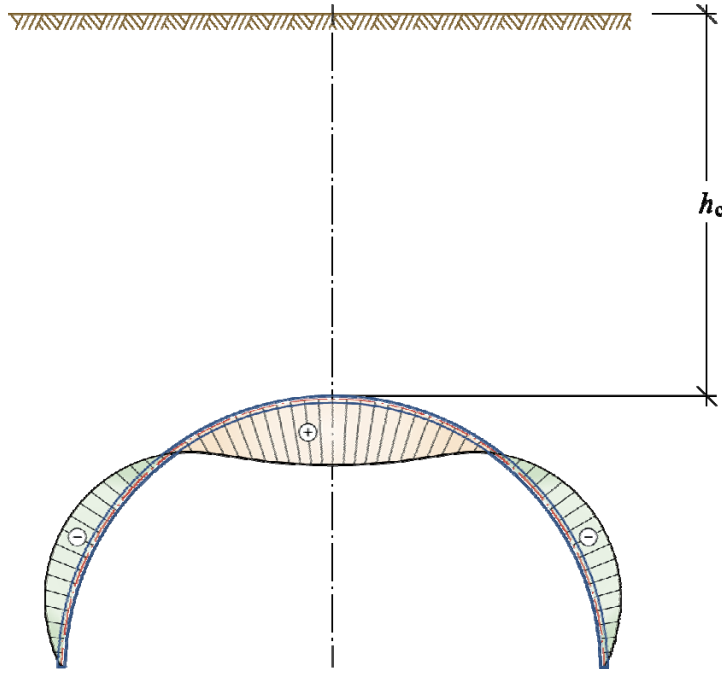

Figure 4.5 With a large depth of covering fill, the moment in the crown may change sign, so that a positive moment is experienced in this region. Note that the figure is schematic both in respect of moment signs and sizes.

The variations in the calculated moment due to the surrounding fill and covering fill can be satisfactorily dealt with if the load coefficients related to the soil material's dead weight (maximum and minimum) are taken into consideration. This means, for example, that for the material used in the backfill up to the level of the crown a high load coefficient can be used, whereas a low coefficient may be more appropriate for another material in the backfill above the crown. The different soil materials shall thus be considered individually when determining the design bending moment due to the soil load. The same soil material need not be given different load coefficients if it is used both below and above the crown level.

In the case of profiles where $R_t / R_s \geq 1$, the moment in the side plates is calculated as 2/3 of the moment calculated according to:

$$M_{\text{soil},k} / D^3 = M_{\text{soil},\text{surr},k} / D^3 + M_{\text{soil},\text{cover},k} / D^3 = -\rho_{\text{surr}} f_1 f_3 f_{2,\text{surr}} +$$

$$+ S_{\text{ar}} \rho_{\text{cover}} \frac{h_{\text{c,red}}}{D} \left(\frac{R_t}{R_s} \right)^{0,75} f_1 f_{2,\text{cover}} \quad (4.q)$$

$$R_t / R_s \geq 1,0$$

The function f_1 is calculated as:

$$\text{if } 0,2 < H/D \leq 0,35: \quad f_1 = [0,67 + 0,87(H/D - 0,2)] \quad (4.r')$$

$$\text{if } 0,35 < H/D \leq 0,5: \quad f_1 = [0,8 + 1,33(H/D - 0,35)] \quad (4.r'')$$

$$\text{if } 0,5 < H/D \leq 0,6: \quad f_1 = 2 \cdot (H/D) \quad (4.r''')$$

f_2 is calculated as :

$$\text{if } \lambda_f \leq 5000 : f_{2,\text{surr}} = 0,0046 - 0,0010 \cdot 10 \log(\lambda_f) \quad (4.s') \quad (4.s'')$$

$$\text{if } \lambda_f > 5000 : f_{2,\text{surr}} = 0,0009 \quad (4.s''')$$

and f_3 is calculated as

$$f_3 = 6,67 \frac{H}{D} - 1,33 \quad (4.s''')$$

The functions f_1 and f_3 are shown graphically in **Figure 4.6**.

For the backfilling above the crown of the culvert, the following applies

$$\text{if } \lambda_f \leq 5000 : f_{2,\text{cover}} = 0,018 - 0,004 \cdot 10 \log(\lambda_f) \quad (4.s''''')$$

$$\text{if } \lambda_f > 5000 : f_{2,\text{cover}} = 0,0032 \quad (4.s''''''')$$

The functions $f_{2,\text{cover}}$ and $f_{2,\text{surr}}$ are shown graphically in **Figure 4.7**.

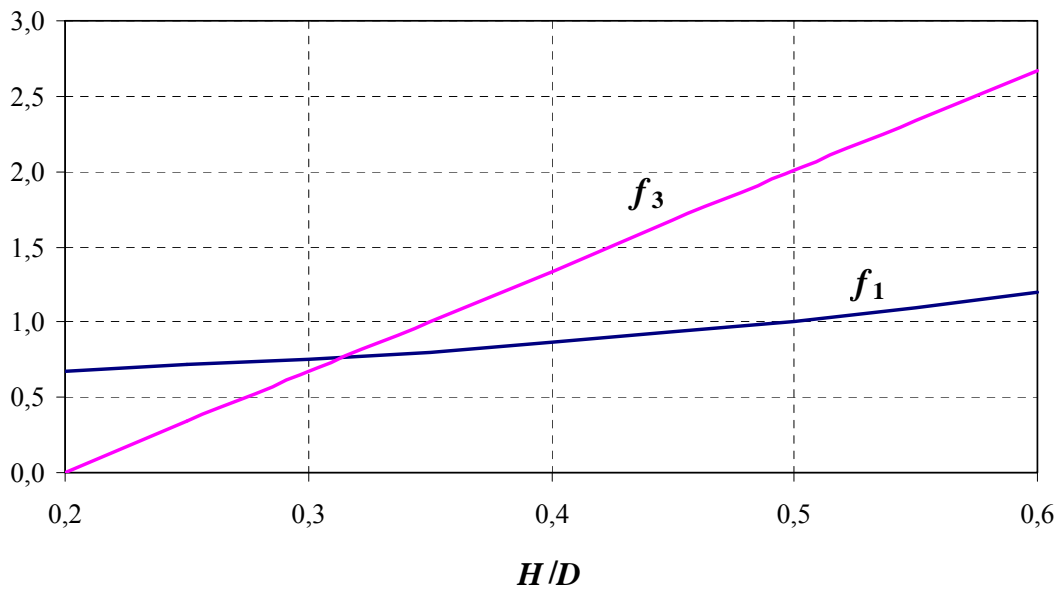

Figure 4.6 The functions f_1 and f_3 as functions of the ratio of the height H to the span D .

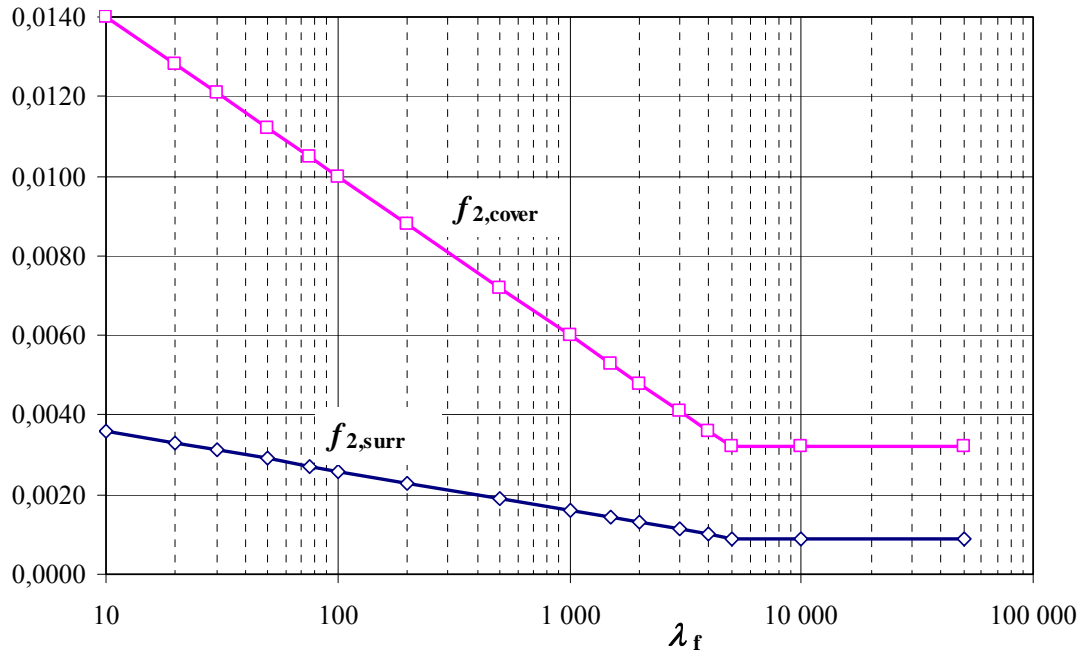

Figure 4.7 The function f_2 plotted as a function of the flexibility number λ_f .

4.5.3 Bending moments due to traffic load

The moment arising from the traffic load (see **Figure 4.8**) due to the equivalent line load p_{traffic} and an evenly distributed traffic load q is given by the equations:

$$M_{\text{traffic},k} = f_4' \cdot f_4'' \cdot f_4''' \cdot f_4^{IV} D \cdot p_{\text{traffic},k} + S_{\text{ar}} \left(\frac{R_t}{R_s} \right)^{0,75} f_1 \cdot f_{2,cover} \cdot q_k D^2 \quad (4.t)$$

$$f_4' = 0,65 \cdot (1 - 0,2 \cdot 10^{\log(\lambda_f)}) \quad (4.u)$$

$$f_4'' = 0,120 \cdot (1 - 0,15 \cdot 10^{\log(\lambda_f)}) \quad (4.v)$$

$$f_4''' = 4 \cdot 0,01^{(h_{c,red}/D)} + 0,4 \quad (4.x)$$

$$f_4^{IV} = \left(\frac{R_t}{R_s} \right)^{0,25} \quad (4.y)$$

In addition, the condition $f_4' \cdot f_4''' < 1,0$ shall always apply.

In the case of profiles where $R_t / R_s \geq 1$, the moment in the side plates is calculated as 1/3 of the moment calculated according to Eq. (4.t).

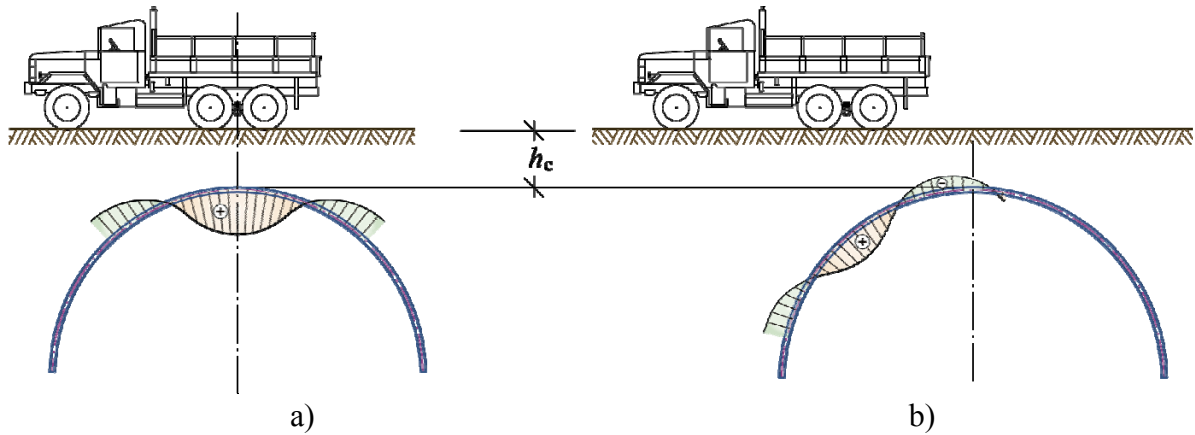

Figure 4.8 A schematic description of the moment distribution
a) when the design load is above the crown, and
b) when the load is positioned in such a way that the largest moment is at the sides of the culvert profile.

In the case of a culvert with a horizontal elliptical shape or a box culvert, the moment distribution corresponding to the condition in **Figure 4.8 a)** is approximately as indicated in **Figure 4.9**.

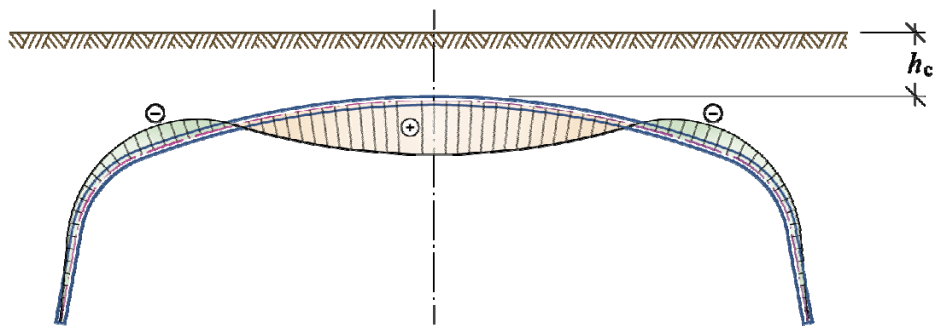

Figure 4.9 The moment distribution in a horizontal ellipse or box culvert under the traffic load which gives the largest moment. Note that the figure is schematic.

Eqs. (4.u) and (4.v) are shown in **Figure 4.10**.

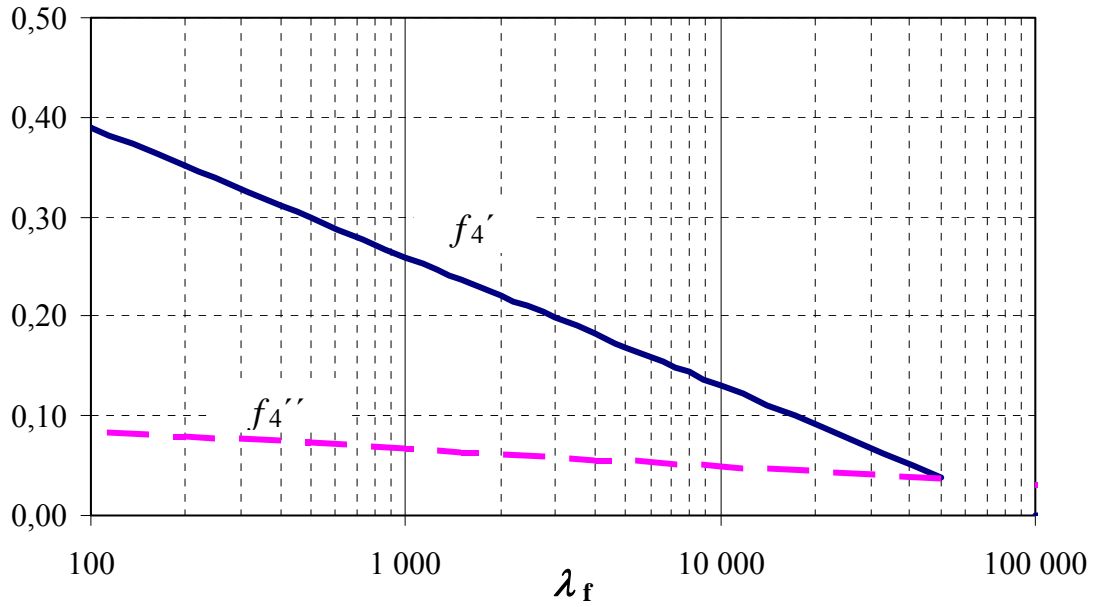

Figure 4.10 Parameters f_4' and f_4'' used when calculating the moment due to traffic loads.

Eq. (4.x) is shown graphically in **Figure 4.11**, and Eq. (4.y) is shown in **Figure 4.12**.

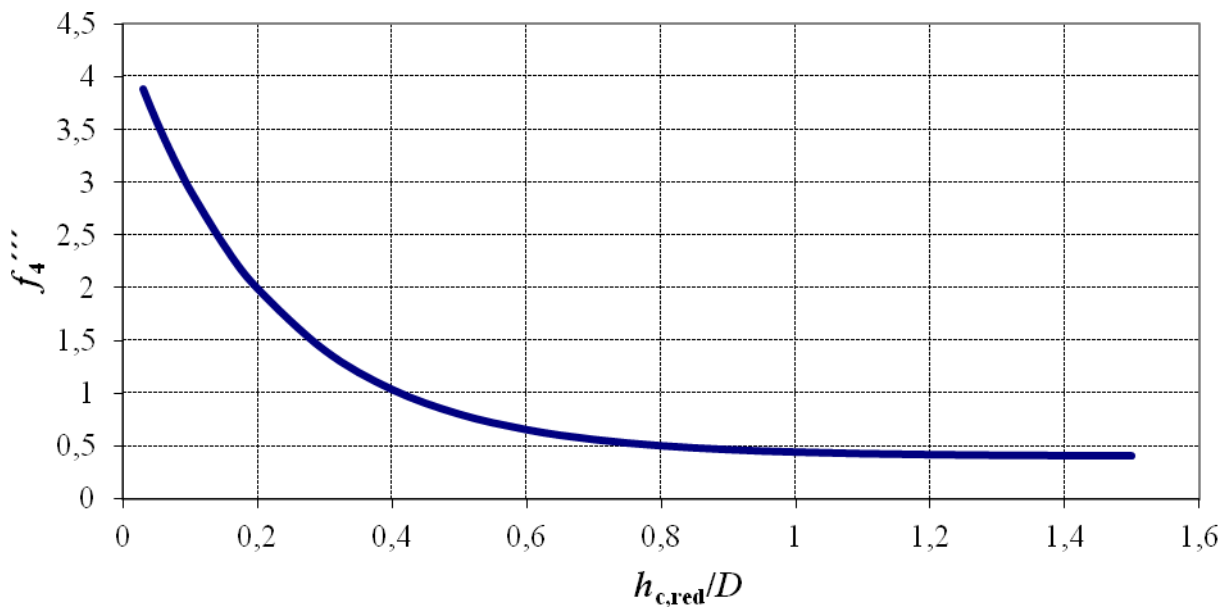

Figure 4.11 Parameter f_4''' used when calculating the moment due to the traffic loading as a function of the relative depth of cover.

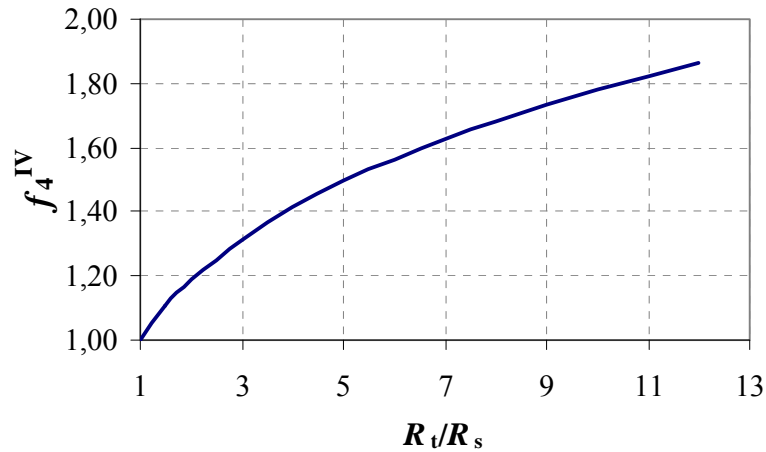

Figure 4.12 Parameter f_4^{IV} used when calculating the moment due to the traffic loading as a function of the ratio R_t/R_s .

4.5.4 Distribution of moments in a culvert with varying cross-section

A culvert is usually designed with a constant cross-section and, as indicated above, this means that it is only necessary to calculate the moment-bearing capacity in the crown where the stresses due to bending are largest. In some cases, however, it can be more economical to use reinforcing plates to increase the load-bearing capacity in the most exposed regions, as shown in **Figure 4.13**. The necessary dimensions of these reinforcing plates are calculated according to the principles indicated in **Figure 4.14**, which shows schematically the moment distributions for both soil and traffic loads.

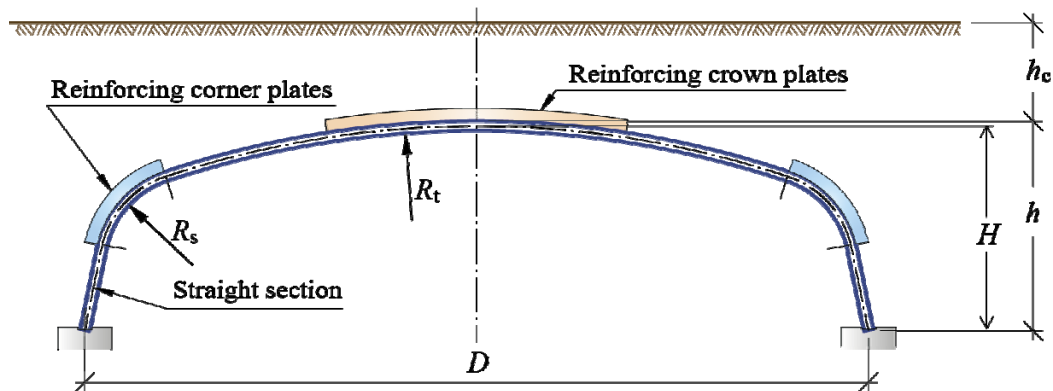

Figure 4.13 It can in some cases be appropriate to reinforce the cross-section with reinforcing plates.

The design corner moment, as indicated in **Figure 4.14**, is the combined moment due to soil and traffic loads according to the principle:

$$\begin{aligned}
 & \text{Dimensioning corner moment} \\
 & = 2/3 \text{ of the crown moment due to soil load} \\
 & + 1/3 \text{ of the crown moment due to traffic load}
 \end{aligned}
 \tag{4.z}$$

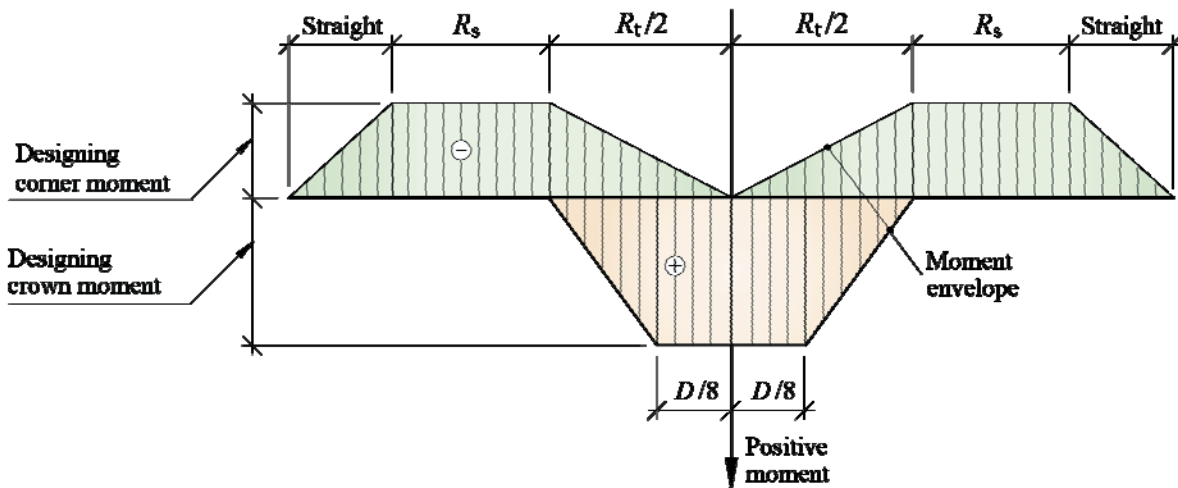

Figure 4.14 The principles for the determination of the moment distribution in box culverts and, where appropriate, in horizontal elliptical culverts¹⁵.

In some cases the use of so called reinforcement plates is necessary¹⁶. Reinforcement plates are corrugated plates bolted to the culvert profile where it is found necessary. Reinforcement plates may be continuous or intermittent. In the case with continuous plates the design is straight forward using the section parameters for the two plates bolted together.

In the case with intermittent plates, for example as shown in **Figure 4.13**, the calculation of section forces starts with the un-reinforced culvert profile (often referred to as the “barrel”). If reinforcement is deemed necessary a preliminary amount of reinforcement plates is determined by adding plates until the bending capacity of the composite section is high enough comparing the bending capacity with the design bending moment. Both haunch area as well as the crown area should be checked. The length of the plates is determined by extending the plates until the section is found where the capacity of the basic culvert profile (barrel) is high enough on its own. The moment distribution is shown in **Figure 4.14**.

After the amount and length of the reinforcement plates have been estimated the culvert profile is checked in the same way as a culvert without reinforcement plates using the section parameters for the composite section. If the length of the reinforcement plate in the crown area is less than the length of the top radius plate the bending stiffness EI should be replaced with an equivalent bending stiffness for the composite section taking the length of the reinforcement plate relative to the crown plate length into account.

With this preliminary layout and size of the strengthening plates the stiffness of the strengthened culvert profile should be determined in order to calculate section forces for the now stiffer culvert. This is done according to the principles above by calculating a new stiffness number for the culvert now stiffened by the reinforcing plates, compare *Pettersson (2007)*.

¹⁵ The chain of dimensions in the figure refers to those parts of the culvert which have different radii, not different measures, cf. Figure 1.3 H.

¹⁶ Note that this section deals with two radius arches and box culverts only.

The design procedure is then re-iterated until the capacity of the strengthened profile is high enough.

It should be noted that the slippage between the two plates in a reinforced section has to be taken into account when determining the section parameters compare for example *Bakht & Newhook (2004)* and *Machelski (2013)*.

4.5.5 Design bending moments

The design bending moments due to soil and traffic loads have different signs at different points and checks must therefore be performed according to the following formulae.

The design moment in the serviceability limit state is determined according to:

$$M_{d,SLS} = \gamma_{soil,surr,SLS} M_{soil,surr,k} + \gamma_{soil,cover,SLS} M_{soil,cover,k} + \gamma_{traffic,SLS} M_{traffic,k} \quad (4.w')$$

The design moment for a traffic load in the serviceability limit state is determined according to:

$$\left. \begin{aligned} M_{traffic,SLS}^{max} &= \gamma_{traffic,SLS} \cdot M_{traffic,k} \\ M_{traffic,SLS}^{min} &= \gamma_{traffic,SLS} \cdot (-M_{traffic,k} / 2) \end{aligned} \right\} \quad (4.w'')$$

In the ultimate limit state, the design moment is calculated according to

$$M_{d,ULS} = \gamma_d \left[\gamma_{soil,surr,ULS} M_{soil,surr,k} + \gamma_{soil,cover,ULS} M_{soil,cover,k} + \gamma_{traffic,ULS} M_{traffic,k} \right] \quad (4.aa')$$

where γ_d is the partial coefficient for safety class, see *EKS 9* or *TRVFS 2011:12*.

The design moment for a traffic load in the ultimate limit state is determined according to:

$$\left. \begin{aligned} M_{traffic,ULS}^{max} &= \gamma_{traffic,ULS} \cdot M_{traffic,k} \\ M_{traffic,ULS}^{min} &= \gamma_{traffic,ULS} \cdot (-M_{traffic,k} / 2) \end{aligned} \right\} \quad (4.aa'')$$

In the fatigue limit state the design bending moment is calculated by:

$$M_{traffic,d,FAT} = \gamma_{traffic,FAT} \cdot M_{traffic,k,FAT} \quad (4.ab)$$

The values of the partial coefficients recommended by the relevant authority are inserted in the above equations.

5. Design

5.1 Verification of the load-bearing capacity

The following checks on the load-bearing capacity are necessary in a full-scale design analysis of a culvert. Checks A, B and D refer to design situation STR and check C refers to design situation FAT. Items A 1. and B 1. shall also be checked with respect to the construction stage. In certain cases other checks than those stated below may be necessary.

A. Calculation checks in the serviceability limit state, **Section 5.2.**

1. Check of the safety against the onset of yielding in the wall of the pipe, **Section 5.2.1.**
2. Calculation of settlement in the entire volume of soil surrounding the culvert, **Section 5.2.2.**

B. Calculation checks on the load-bearing capacity of the wall of the pipe in the ultimate limit state, **Section 5.3.**

1. Check that plastic hinges or plastic hinge mechanisms do not arise in the upper part of the pipe, **Section 5.3.1.**
2. Check that buckling does not occur in the lower part of the pipe, **Section 5.3.2.**
3. Check that the strength of the bolted connections is not exceeded, **Section 5.3.3.**
4. Check for safety against the radial soil pressure against the corner plates in the so-called pipe arches profiles, and in profiles for underpasses, **Section 5.3.4.**
5. Check the load-bearing capacity of concrete footings (applies only to arched culverts), **Section 5.3.5.**

C. Fatigue design, **Section 5.4**

1. General and fatigue soil modulus, **Section 5.4.1.**
2. Load actions used for fatigue design, **Section 5.4.2.**
3. Fatigue capacity of the steel plates, **Section 5.4.3.**
4. Fatigue capacity of the bolts, **Section 5.4.4.**

D. Construction stage, **Section 5.5**

1. Check that the construction has adequate stiffness during installation, handling etc. (so-called “handling stiffness”), **Section 5.5.1.**
2. Check of structure at zero cover depth, **Section 5.5.2.**
3. Check of the structure in temporary construction stages, **Section 5.5.3.**

The above checks are made according to the methods described below.

5.2 Checks in the serviceability limit state

5.2.1 Ensuring safety against the onset of yielding in the serviceability limit state

The maximum stress in the wall of the pipe is calculated using Navier's equation

$$\sigma = \frac{N_{d,SLS}}{A} + \frac{M_{d,SLS}}{W} < f_{yd} \quad (5.a')$$

The design soil modulus used in checking the maximum wall stress, $E_{soil,SLS,d}$, is calculated using Eq. (b2.i) but multiplied by a factor f_5 see Eq. (5.a'')

$$f_5 = 1,5 \quad (5.a'')$$

Where the factor “1,5” is for converting from ULS to SLS. Note that the requirement $\lambda_f \leq 50\,000$ shall be fulfilled setting a limit for the maximum soil modulus to be used in the calculations. Note that the higher soil modulus used in the serviceability limit state should be used for the traffic load only.

The design normal force and bending moment are calculated as the sum of the absolute values of the maximum normal force and the maximum bending moment calculated separately for the soil load and the traffic load, using the equations given in **Chapter 4**. The partial coefficients used are those applicable to the serviceability limit state. A check is made to ensure that the yield stress f_{yd} of the steel material is not exceeded in the upper part of the walls of the pipe during the service load condition. Values for A and W could be found in **Appendix 1** for commonly used corrugated sections.

5.2.2 Settlements in the surrounding soil

For this part of the design reference is made to geotechnical standards and specifications.

5.3 Checks in the ultimate limit state

The section properties of the plates used for culverts is almost always in cross-section class 1 or 2, meaning that reduction due to risk for local buckling can normally be omitted. For notations see **Figure B1.3** – **Figure B1.6**. The formulae presented in this section are thus simplified using the assumption that the plates are in cross-section class 2 or lower.

5.3.1 Check against the development of a plastic hinge in the upper part of the pipe.

At the ultimate limit state, a check is made on the maximum loaded section using *EN 1993-1-1* expression (6.61). As the plate is presumed not to deflect laterally (z -axes),

$\chi_{LT} = 1,0$ and $\chi_z = 1,0$. Furthermore, the moments $M_{z,Ed} = \Delta M_{z,Ed} = 0$ and, as the neutral axis does not change due to local buckling, $\Delta M_{y,Ed} = 0$.

The expression (6.61) in *EN 1993-1-1* can thus be simplified to

$$\frac{N_{Ed}}{\chi_y N_{Rk}} + k_{yy} \frac{M_{y,Ed}}{M_{y,Rk}} \leq 1,0 \quad (5.b)$$

$N_{Ed}, M_{y,Ed}$

design value for axial force and bending moment,

$N_{d,ULS}, M_{d,ULS}$. Observe that in certain cases the moment capacity, $M_{y,Rk}$, should be reduced according to Eq. (b1.h)

$$\chi_y = \frac{N_{cr}}{N_u}$$

reduction factor for flexural buckling, see 6.3.1 in *EN 1993-1-1*

k_{yy}

interaction factor according to Table A.1 and A.2 in Appendix A in *EN 1993-1-1*. Note that method 1 is recommended in the Swedish National Annex.

$N_{Rk} = f_y A$ and $M_{y,Rk} = f_y W$ resistance for axial force and bending moment.

$\gamma_{M1,steel}$ = material partial coefficient for steel (instability, recommended value 1,0)

The interaction factor k_{yy} can be simplified considerably. For cross-section classes 1 and 2 it is

$$k_{yy} = \frac{C_{my}}{\left(1 - \chi_y \frac{N_{Ed}}{N_{cr,y}}\right) C_{yy}} \quad (5.c)$$

where $C_{my} = C_{my,0}$ is a correction factor allowing for the distribution of the moment along the arch according to Tables A.1 and A.2 in *EN 1993-1-1*. It can be assumed that $C_{my} = 1,0$. $N_{cr,y} = N_{cr,el}$ according to Eq. (B5.b).

For cross-section classes 1 and 2 the correction factor C_{yy} is added. As $\bar{\lambda}_0 = 0$ and $\bar{\lambda}_z = 0$, the expression for C_{yy} in Table A.1 can be simplified to

$$C_{yy} = 1 + (w_y - 1) \left[\left(2 - \frac{1,6}{w_y} C_{my}^2 \bar{\lambda}_y (1 + \bar{\lambda}_y) \right) \cdot \eta_{pl} \right] \quad (5.d)$$

and

$$C_{yy} \geq \frac{W_{el,y}}{W_{pl,y}} \quad (5.e)$$

where $w_y = \frac{W_{pl,y}}{W_{el,y}} \leq 1,5$ is the quotient between plastic and elastic section modulus.

The relative slenderness $\bar{\lambda}_y$ is given by

$$\bar{\lambda}_y = \sqrt{\frac{N_u}{N_{cr,el}}} \quad (5.f)$$

where N_u , $N_{cr,el}$ and N_{cr} are given in **Appendix 5**. In the calculation of N_{cr} in accordance with **Appendix 5**, ξ is set equal to 1,0.

Check should also be done with ξ calculated according to **Appendix 5**, Eq. (B5.e) checking the relation $(N_{d,ULS} / (\omega f_{yd} A))^{\alpha_c} \leq 1,0$, with $\alpha_c = \eta^2 \cdot \omega \geq 0,8$; $\eta = Z / W$. For the profile types listed in **Appendix 1**, $\eta \cong 1,35$ unless some other value is shown to be more correct.

For helically corrugated pipes which are cold-formed to so called low-rise profiles, Eq. (5.b) can be used provided N_{Rk} and M_{Rk} are divided by the factor 1,15.

5.3.2 Check for sufficient capacity in the lower part of the pipe

Under item B.1 above, the capacity is checked with regard to the pipe's upper part with radius R_t . In addition, the capacity of all sections of the pipe with a constant radius shall be checked with respect to prevailing normal forces. The normal force is considered to be the same around the profile and to be equal to the largest design value according to **Section 4.3.6**.

The capacity is checked with respect to the condition

$$N_{d,ULS} \leq N_{cr} \quad (5.g)$$

where N_{cr} is calculated as indicated in **Appendix 5** with the following changes:

$$\eta_j = \xi = 1 \quad (5.h)$$

and

$$\mu = 1,22 \quad (5.i)$$

and where R_t in Eq. (b5.g) is replaced by the radius of the section concerned.

5.3.3 Ensuring safety against exceeding the capacity of the bolted connections

The bolted connections shall be designed in such a way that the prevailing normal forces and bending moments can be transferred. The suggested input data for the capacities are chosen after testing of connections built up by the special kinds of bolts used for these kinds of structures.

5.3.3.1 Bending capacity of the bolted connection

The distance between parallel rows of bolts to obtain the required moment capacity (when the number of bolts, n , is known) in the joint, see **Figure 5.1** is obtained using Eq. (5.j)

$$a \frac{n}{2} F_{t,Rd} \geq W \cdot f_{yd} \quad (5.j)$$

where

$$F_{t,Rd} = \frac{0,9 f_{u,bolt,k} \cdot A_{bolt}^{net}}{\gamma_{M2}} \quad (5.k)$$

If a becomes unreasonably large, n should be increased. Note that in Eq. (5.j) the number of bolts in the bolt rows is the same. Assuming a linear distribution of the bending strain over the bolted connection all rows of bolts may be included when the capacity is calculated. For non-symmetrical bolted connections (the number of bolts is not the same in the rows) only bolts constituting a symmetrical bolt arrangement may be included in the connection bending capacity.

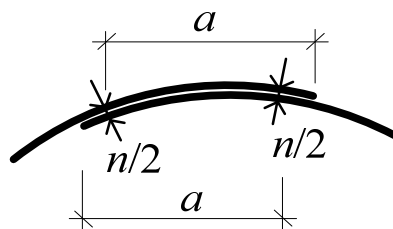

Figure 5.1 Notations used when determining the distance between bolts.

5.3.3.2 Shear

On condition that the bolted connections, for every adjacent crest/trough at least two bolts are used and that their positions are chosen so that the bending moment can be transferred, the capacity of the connection may be calculated using *EN 1993-1-8*, Table 3.4 after inserting the relevant data for bolt material and dimensions. That the capacity is adequate may be checked by using equation (5.l) where the design normal force, $N_{d,ULS}$, consists of the sum of the soil

load and traffic load with partial coefficients as specified by the respective authority. In a joint, the number of bolts n required per metre width of the culvert is determined according to

$$N_{d,ULS} < \min(n \cdot F_{v,Rd}; n \cdot F_{b,Rd}) \quad N_{d,ULS} < \min(n \cdot F_{v,Rd}; n \cdot F_{bolt,Rd}) \quad (5.l)$$

$$F_{v,Rd} = \frac{0,6 f_{u,bolt,k} A_{bolt}^{net}}{\gamma_{M2}} \quad (5.m)$$

the equation for the bearing capacity can, for commonly used bolted connection geometries, be simplified to

$$F_{b,Rd} = \frac{2,5 f_{uk} \cdot d_{bolt} \cdot t}{\gamma_{M2}} \quad (5.n)$$

For other geometries the *EN 1993-1-8*, table 3.4 equations should be used.

5.3.3.3 Tension

The tensile force in the bolts is calculated according to

$$F_{t,ULS} = \frac{2 \cdot M_{d,ULS}}{a \cdot n} \quad (5.o)$$

5.3.3.4 Interaction

In the ultimate limit state, the case of combined tension and shear shall be checked according to formula

$$\frac{F_{v,ULS}}{F_{v,Rd}} + \frac{F_{t,ULS}}{1,4 \cdot F_{t,Rd}} \leq 1,0 \quad (5.o)$$

where the shear force in the bolts is calculated according to

$$F_{v,ULS} = \frac{N_{d,ULS}}{n} \quad (5.p)$$

5.3.4 Check that the radial soil pressure against the lower corner plates is not too big

No special check with respect to the radial soil pressure is required with regard to the values of the radii given in **Section 1.2.3**. In other cases, it is recommended that special checks be made with regard to the soil pressure and the risk of upward pressure on the bottom plates of the pipe.

For checking the pressure on the corner plates the following approximate formula can be used

$$p_c = \frac{R_t}{R_c} p_t \quad (5.q)$$

where

p_c is the radial pressure acting on the corner plates and

p_t is the radial pressure acting on the top plates.

5.3.5 Check of the concrete or steel foundation slabs (arch type culvert profiles and box culverts only)

This report does not specifically deal with the design of foundations of concrete or other material, since such a calculation should be performed in the same manner as for other bridges. The steel arch affects the foundation with a design normal force calculated as described above. The moment from the arch does not need to be considered here (an arch is normally installed moment-free in the foundations in cast-in steel channels with a U-profile). A hint on the needed forces for ensuring the equilibrium of a footing is shown in **Figure 5.2**.

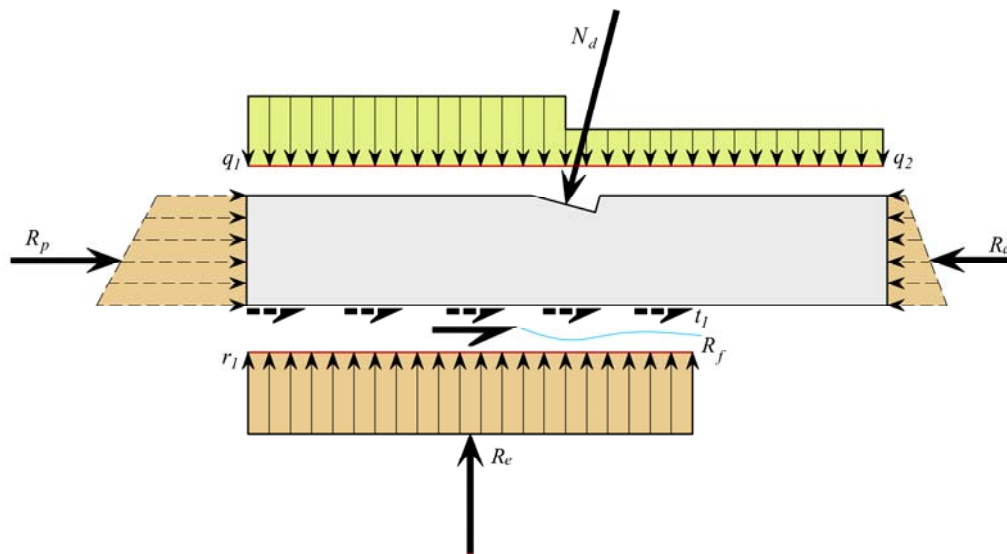

Figure 5.2 Principles for forces acting on a footing to arches and box culverts. The force R_e defines the effective width of the soil pressure.

5.4 Fatigue design

5.4.1 General and fatigue soil modulus

The fatigue capacity of the steel plates and the bolted connections should be checked. For the bolted connections both the steel plates close to the connection and the bolts in the connection should be checked.

The design soil modulus used in checking the fatigue capacity, $E_{\text{soil,FAT,d}}$, is calculated using Eq. (b2.i) but multiplied by a factor f_6 see Eq. (5.r)

$$f_6 = 1,5 \cdot 1,5 \quad (5.r)$$

Where the first factor “1,5” is for converting from ULS to SLS and the second factor “1,5” for long term soil effects. Note that the requirement $\lambda_f \leq 50\,000$ shall be fulfilled setting a limit for the maximum soil modulus to be used in the calculations. Note that the higher soil modulus used in the fatigue design should be used for the traffic load only.

The fatigue design methodology and detail categories are based on testing of bolted connections having hot dip galvanized self-centering bolts with flange bolts and nuts M20, 8.8, tightened to minimum 300 Nm, *Martino (2014)*.

The positive effect of part of the stress range being in compression can be taken into account according to the provisions in *EN 1993-1-9, 7.2.1(2)*.

For road bridges the fatigue capacity should be verified using the accumulated damage method. For railway bridges the lambda method should be used, compare *EN 1991-2*.

5.4.2 Load actions used for fatigue design of road bridges

Fatigue live load model FLM4 is to be used, see *EN 1991-2*. The accumulated damage should be calculated for the vehicle axles one by one (the effect of closely spaced axles should not be taken into account).

Because the vehicle position, in the transverse direction, is not the same for all passages (see *EN 1991-2, 4.6.1(5)*), the stress ranges are allowed to be reduced according to:

50 % of the passages: no reduction of calculated stress ranges

36 % of the passages: 97 % of the calculated stress ranges

14 % of the passages: 90 % of the calculated stress ranges

5.4.3 Fatigue capacity of the steel plates

The live load steel plate stress range at the crown for one axle passing the structure should be calculated for the top fibre of the corrugated steel wall as well as the bottom fibre. The stress ranges are calculated according to the following equations

$$\sigma_{\text{traffic,FAT,max}}^{\text{top}} = 0,20 \frac{M_{\text{traffic,d,FAT}}}{W} \quad ; \quad \sigma_{\text{traffic,min}}^{\text{top}} = -\frac{N_{\text{traffic,d,FAT}}}{A} - \frac{M_{\text{traffic,d,FAT}}}{W} \quad (5.s)$$

$$\Delta\sigma_{\text{traffic,d,FAT}}^{\text{top}} = \frac{N_{\text{traffic,d,FAT}}}{A} + 1,20 \frac{M_{\text{traffic,d,FAT}}}{W} \quad (5.t)$$

$$\sigma_{\text{traffic,min}}^{\text{bottom}} = -\frac{N_{\text{traffic,d,FAT}}}{A} - 0,20 \frac{M_{\text{traffic,d,FAT}}}{W} ;$$

$$\sigma_{\text{traffic,max}}^{\text{bottom}} = -\frac{N_{\text{traffic,d,FAT}}}{A} + \frac{M_{\text{traffic,d,FAT}}}{W} \quad (5.u)$$

$$\Delta\sigma_{\text{traffic,d,FAT}}^{\text{bottom}} = 1,20 \frac{M_{\text{traffic,d,FAT}}}{W} \quad (5.v)$$

$N_{\text{traffic,d,FAT}}$ and $M_{\text{traffic,d,FAT}}$ are calculated for each of the axles in the fatigue load model FLM4 using Eq. (4.l) and (4.t). Design curves where $p_{\text{traffic,k,FAT}}$ has been calculated for different cover depth and the different axles included in fatigue load model FLM4 can be found in **Appendix 8**.

For the steel plates the capacity is checked at the crown. Detail category = 125.

5.4.4 Fatigue capacity of the bolted connections

The live load steel plate stress ranges at the bolted connections can be calculated using Eqs. (5.s) – (5.v).

A reduction of the live load bending moment, M_{traffic} , is possible if the connection is not placed at the crown. The live load bending moment can be reduced using the following factor, compare **Figure 5.3**.

$$\left(\frac{h_c}{h_f} \right)^2 \quad (5.x)$$

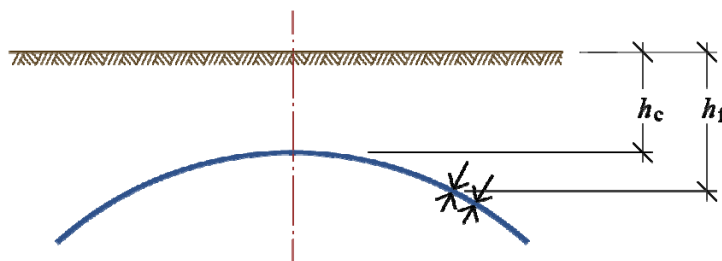

Figure 5.3 When the joints are situated at positions with greater depth of cover than at the crown, the designing moment due to fatigue can be reduced.

For the steel plates the detail category = 90 and $m = 5$.

The live load bolt stress ranges for one axle passing the structure is calculated according to the following equations. The tensile and shear stress ranges are simultaneous.

$$\Delta\sigma = 0,8 \cdot \frac{2 \cdot M_{\text{traffic,FAT}}}{a \cdot A_{\text{bolt}}^{\text{net}} \cdot n} \quad (5.y)$$

Detail category (tension) = 50. The factor 0,8 takes the effect of bolt tightening into account.

$$\Delta\tau = \frac{N_{\text{traffic,FAT}}}{A_{\text{bolt}}^{\text{net}} \cdot n} \quad (5.z)$$

Detail category (shear) = 100, $m = 5$.

5.5 Construction stage

The structural behaviour of a Soil-Steel composite structure is dependent of a proper construction process and that the steel structure is not deformed during this process, thus some checks must be performed.

5.5.1 Check to ensure that the construction has adequate rigidity during installation and handling etc.

It is recommended that the steel pipe's stiffness defined as

$$\eta_m / (\text{m} / \text{kN}) = \frac{D^2}{(EI)_{\text{steel}}} \quad (5.aa)$$

is given a value such that

$$\eta_m / (\text{m} / \text{kN}) < 0,13 \text{ for circular sections, and}$$

$$\eta_m / (\text{m} / \text{kN}) < 0,20 \text{ for arched and low-rise sections.}$$

5.5.2 Check of the structure at zero cover depth

As illustrated in **Figure 4.4 a)** the stress in the culvert wall at the crown at zero cover depth need to be checked. The normal force and the bending moment should be calculated using equations (4.c) and (4.q). Note that only parts of the equations corresponding to zero cover depth should be used. Navier's equation should be used to check that the design yield stress is not exceeded.

5.5.3 Check of the structure in temporary construction stages

During construction the structure may experience cover depth and loads other than those used for the design of the permanent structure. Since these construction stages may be critical for the structure, they need to be checked in the same way as for the permanent structure.

6. References and literature

6.1 References

Note that the references are shown per chapter and appendix respectively. The references are listed in the order they appear.

Chapter 1

- BSK 99 *Boverkets handbok om stålkonstruktioner*, Boverket, 1999. (In Swedish, The National Board of Housing, Building and Planning: Design standard for steel structures.)
- ATB BRO 94 *Vägverkets allmänna tekniska beskrivning för broar*, Vägverket 1994. (In Swedish, Swedish Road Administration 1994: earlier Swedish standard for bridges)
- ATB Rörbroar *Vägverkets allmänna tekniska beskrivning för rörbroar*, Vägverket 1999. (In Swedish, Swedish Road Administration 1999: earlier Swedish standard for Soil-Steel Composite Bridges)
- TRVK Bro 11 Swedish requirements for bridges, Trafikverket 2011, TRV publ. 2011:085 (in Swedish).
- TRVR Bro 11 Swedish recommendations for the dimensioning and design of bridges. Trafikverket 2011, TRV publ. 2011:086. (in Swedish)
- Duncan, J. M., (1977) *Behaviour and Design of Long-Span Metal Culvert Structures*, ASCE Convention Soil-Structure Interaction for Shallow Foundations and Buried Structures, San Francisco, USA, October 1977.
- Duncan, J. M., (1978) *Soil-Culvert Interaction Method for Design of Metal Culverts*, Transportation Research Record 678 (Tolerable Movement of Bridge Foundations, Sand Drains, K-Test, Slopes, and Culverts), Transportation Research Board, National Academy of Sciences, Washington D.C., USA, 1978.
- Duncan, J. M., (1979) *Behaviour and Design of Long-Span Metal Culverts*, Journal of the Geotechnical Eng. Div., Mars 1979.
- Pettersson, L., Persson, H., (1984) *Fullskaleförsök på lågbyggd trumma*, Examensarbete vid institutionen för brobyggnad, KTH, 1984.
- Temporal, J., Barrat, D. A., Hunnibell, B. E. F. (1985) *Loading tests on an Armco pipe arch culvert*. Transport and Road Research Laboratory, Research Report no 32, Berkshire, UK, 1985.
- Beben, D. and Manko, Z., (2002) *SuperCor BoxCulvert, SC 56B, Gimån, Sweden*, University of Opole and Technical University of Wroclaw, Test report October 2002.
- Pettersson, L., (2007) *Full Scale Tests and Structural Evaluation of Soil Steel Flexible Culverts with low Height of Cover*, Doctoral Thesis in Civil and Architectural Engineering, Division of Structural Engineering and Bridges, TRITA_BKN Bulletin 93, KTH Royal Institute of Technology, Stockholm, Sweden, 2007.

- Flener, E. B., (2009) *Static and dynamic behaviour of soil-steel composite bridges obtained by field testing*, TRITA-BKN. Bulletin 98, KTH, Stockholm 2009.
- Pettersson, L. & Wadi, A. (2013) *Full scale live load tests on older Soil-Steel Composite Bridges close to Skellefteå, Sweden*, (test report) KTH Structural Engineering and Bridges, 2013.
- Vaslestad, J., (1990) *Soil Structure Interaction of Buried Culverts*, Institutt for Geoteknikk, Norges Tekniske Högskole Universitetet i Trondheim, 1990.
- Andréasson, L., (1973) *Kompressibilitet hos friktionsjord. Laboriestudium, Byggeforskningen. Rapport R36:1973.*
- Klöppel, K., Glock D., (1970) *Theoretische und experimentelle Untersuchungen zu den Traglastproblemen biegeweicher, in die Erde eingebetteter Rohre, Heft 10, Veröffentlichung des Institutes für Statik und Stahlbau der Technischen Hochschule Darmstadt, Darmstadt 1970.*
- BSK99 and BSK 07 *Boverkets handbok om stålkonstruktioner*, Boverket, 1999 and 2007 respectively. (In Swedish, The National Board of Housing, Building and Planning: Design standard for steel structures.)
- Pettersson, L., (1998) *Full Scale Live Load Tests on a Corrugated Steel Culvert, IABSE Colloquium Tunnel Structures*, 1998.
- Flener, E. B., (2003) *Field Testing of a Long-span Arch Steel Culvert Railway Bridge over Skivarpsån, Sweden. Part I*, TRITA-BKN, Rapport 72, KTH, Stockholm, 2003.
- Flener, E. B., (2004) *Field Testing of a Long-span Arch Steel Culvert Railway Bridge over Skivarpsån, Sweden. Part II*, TRITA-BKN, Rapport 84, KTH, Stockholm, 2004.
- Flener, E. B., (2005) *Field Testing of a Long-span Arch Steel Culvert Railway Bridge over Skivarpsån, Sweden. Part III*, TRITA-BKN, Rapport 91, KTH, Stockholm, 2005.
- Flener, E. B., (2006) *Full Scale Testing of Two Corrugated Steel Box Culverts with Different Crown Stiffness*, TRITA-BKN. Rapport 93, KTH, Stockholm 2006
- Flener, E. B., (2008) *Full-scale Testing of Two Corrugated Long Span Steel Box Culverts with Different Crown Stiffness*, TRITA-BKN. Rapport 118, KTH, Stockholm 2008

Chapter 2.

- TRVR Bro 11, Trafikverket (2011) *Swedish recommendations for the dimensioning and design of bridges. TRV publ 2011:086. (in Swedish)*

Chapter 3

- Duncan, J. M., (1979) *Behaviour and Design of Long-Span Metal Culverts, Journal of the Geotechnical Eng. Div., Mars 1979.*
- EN 1991-2 *Eurocode 1: Actions on structures. Part 2: Traffic loads on bridges. CEN 2003.*

- EKS 9 - Boverket (2013)
The National Board of
Housing, Building and
Planning, BFS 2013:10.
- TRVFS, Trafikverket
(2011) The Swedish
Transport Administration,
TRVFS 2011:12
- Smagina, Ž., (2001)
- Boverkets föreskrifter och allmänna råd om tillämpning av europeiska konstruktionsstandarder (eurokoder), Swedish applications for the structural Eurocodes.
- Swedish applications for using the structural Eurocodes for Bridges (in Swedish).
- Dynamic amplification for moving vehicle loads on buried pipes. Evaluation of field-tests*, TRITA-BKN. Master Thesis 161, Structural Design and Bridges 2001.

Chapter 4

- Boussinesq, J., (1883)
- Application des Potentials à L'Etude de L'Equilibre et du Movements des Solides Elastiques*, Gauthier-Villars, Paris.
- EKS 9 - Boverket (2013)
The National Board of
Housing, Building and
Planning, BFS 2013:10.
- TRVFS, Trafikverket
(2011) The Swedish
Transport Administration,
TRVFS 2011:12
- Pettersson, L., (2007)
- Boverkets föreskrifter och allmänna råd om tillämpning av europeiska konstruktionsstandarder (eurokoder), Swedish applications for the structural Eurocodes.
- Swedish applications for using the structural Eurocodes for Bridges (in Swedish).
- Full Scale Tests and Structural Evaluation of Soil Steel Flexible Culverts with low Height of Cover*, Doctoral Thesis in Civil and Architectural Engineering, Division of Structural Engineering and Bridges, TRITA_BKN Bulletin 93, KTH Royal Institute of Technology, Stockholm, Sweden, 2007.
- Bakht, B., and Newhook, J. P., (2004)
- Tests on SuperCor plates with different patterns of rib stiffening*, Ontario Canada.
- Machelski, C., (2013)
- Shear forces in the connection of structural elements under bending*, Studia Geotechnica et Mechanica, Vol. XXXV, No 3, 2013.

Chapter 5

- EN 1993-1-1
- Eurocode 3: Design of steel structures. Part 1-1: General rules and rules for buildings. CEN 2005.
- EN 1993-1-8
- Eurocode 3: Design of steel structures. Part 1-8: Design of joints. CEN 2005.
- Martino, D., (2014)
- Fatigue testing and design methodology for bolted connections in Soil Steel Composite Bridges*, (lic thesis in prep.), KTH Royal Institute of Technology, Stockholm, Sweden, 2014.
- EN 1993-1-9
- Eurocode 3: Design of steel structures. Part 1-9: Fatigue. CEN 2005.
- EN 1991-2
- Eurocode 1: Actions on structures. Part 2: Traffic loads on bridges. CEN 2003.

Appendix 1

Cary, R. L., (1987) *Inelastic Buckling Stability of Corrugations*, TRR 1087, 1987.
Atlantic Industries Ltd (1994) *Haunch resistance test SuperCor*. Report no 94.2650.03, 1994.

Appendix 2

Duncan, J. M., (1979) Behavior and Design of Long-Span Metal Culverts, *Journal of the Geotechnical Eng. Div.*, Mars 1979.

EN 13286-2 Unbound and hydraulically bound mixtures – Part 2: Test methods for laboratory reference density and water content – Proctor compaction, CEN 2010.

Andréasson, L., (1973) *Kompressibilitet hos friktionsjord. Laboratoriestudium*. Byggeforskningen. Rapport R36:1973.

Larsson, R., (1989) *Hållfasthet i friktionsjord (Strength of frictional soils)*, SGI, 1989

Appendix 4

Boussinesq, J., (1883) *Application des Potentials à L'Etude de L'Equilibre et du Movements des Solides Elastiques*, Gauthier-Villars, Paris.

EN 1991-2 Eurocode 1: Actions on structures. Part 2: Traffic loads on bridges. CEN 2003.

TRVFS, Trafikverket (2011) The Swedish Transport Administration, TRVFS 2011:12 Swedish applications for using the structural Eurocodes for Bridges (in Swedish).

Appendix 5

Klöppel, K., Glock D., (1970) Theoretische und experimentelle Untersuchungen zu den Traglastproblemen biegeweicher, in die Erde eingebetteter Rohre, Heft 10, *Veröffentlichung des Institutes für Statik und Stahlbau der Technischen Hochschule Darmstadt*, Darmstadt 1970.

Abdel-Sayed, G., (1978) *Stability of flexible Conduits embedded in Soil*, Canadian Journal of Civil Engineering, No 3, pages 324 – 333, 1978

Appendix 6

EN 1991-2 Eurocode 1: Actions on structures. Part 2: Traffic loads on bridges. CEN 2003.

Appendix 7

Lind, N.C., & Schroff, D.K., (1975) *Utilization of Cold Work in Light Gage Steel*, Journal of the Structural Division, ASCE, Vol. 101, ST1, January, 1975

EN 1993-1-3 Eurocode 3: Design of steel structures. Part 1-3: General rules – Supplementary rules for cold-formed members and sheeting. CEN 2006.

Pettersson L., Wadi, A., (2013) *Full scale live load tests on older Soil-Steel Composite Bridges close to Skellefteå, Sweden*, (test report) KTH Structural Engineering and Bridges, 2013.

TDOK 2013:0267	<i>TRVK Bärighetsberäkning av vägbroar</i> , Trafikverket, (Swedish Transport Administration), 2013 (in Swedish).
BBK94 and BBK04	<i>Boverkets handbok om betongkonstruktioner</i> , Boverket, 1994 and 2004 respectively. (In Swedish, The National Board of Housing, Building and Planning: Design standard for concrete structures.)
BSK94 and BSK 07	<i>Boverkets handbok om stålkonstruktioner</i> , Boverket, 1994 and 2007 respectively. (In Swedish, The National Board of Housing, Building and Planning: Design standard for steel structures.)

Appendix 8

EN 1991-2	Eurocode 1: Actions on structures. Part 2: Traffic loads on bridges. CEN 2003.
-----------	--

6.2 Literature

There is a large amount of interesting papers and books about Steel culverts and soil-steel composite bridges. Some interesting information can be found in the following list:

Abdel-Sayed, G., Bakht, B., Jaeger, L. G., (1994)	<i>Soil-Steel Bridges, Design and Construction</i> , MCGraw-Hill, Inc, New York, 1994.
CAN/CSA-S6-06 (2006)	<i>Canada Highway and Bridge Design Code</i> , 2006, including supplements 2010, 2011 and 2013.
CSPI (2002)	CSPI, Canadian Steel Pipe Institute, <i>Handbook of Steel Drainage & Highway Construction Products</i> , first Ed. 1984, 2nd Ed. 2002
NCHRP 473 (2002)	<i>Recommended specifications for large-span culverts</i> , National Cooperative Highway Research Programme, Report 473, National Academy Press, Washington, USA, 2002
Vaslestad, J., Kunecki, B., and Johansen, T.H., (2007)	<i>Twenty one years of earth pressure measurements on buried flexible steel structure</i> , First European Conference on Buried Flexible Steel Structures, Rydzyna, Poland, 2007.
White, H., L., Layer, J., P., (1960)	<i>The Corrugated Metal Conduit as a compression Ring</i> , Transportation Research Board, National Research Council, Proceedings of the 29th Annual Meeting, Washington D. C., USA, January 1960.

7. Appendices

Appendix 1 – Cross-sectional parameters for common types of corrugation and plate thickness

Some common types of corrugated culvert wall cross-sections are shown in **Figure B1.3** to **Figure B1.6**. The cross-sections consist of circular and straight parts as shown in the figures, and this means that the cross-sections can be characterized by the thickness of the sheet metal, t , the profile height, h_{corr} , the wavelength, c , the radius of curvature r , the angle, α , and the tangential length (straight region), m_t . Between these parameters, there are geometrical relationships, so that α and m_t can be calculated from the other dimensions according to:

$$\left. \begin{aligned} h_{\text{corr}} &= 2r(1 - \cos \alpha) + m_t \sin \alpha \\ c &= 4r \sin \alpha + 2m_t \cos \alpha \end{aligned} \right\} \quad (\text{b1.a})$$

Profile type	α	m_t
125×26	$0,595 + 0,015t$	$21,0 - 1,62t, t \leq 5,0$
150×50	$0,856 + 0,015t$	$34,2 - 1,88t, t \leq 7,0$
200×55	$0,759 + 0,010t$	$37,5 - 1,83t, t \leq 7,0$
381×140	$0,859 + 0,003t$	$115,1 - 1,273t, t \leq 7,0$

Table B1.1 Cross-sectional parameters α and m_t for the different profiles shown in *Figure B1.1 – Figure B1.4*

The cross-sectional data are given for different sheet metal thicknesses¹⁷ in **Table B1.2** to **Table B1.5**, as follows:

Table B1.2: Profile type with corrugation having wavelength (c) · height (h_{corr}) = 125×26, which is often used for helically wound pipes, see **Figure B1.3**

Table B1.3: Profile type with corrugation having wavelength (c) · height (h_{corr}) = 150×50, see **Figure B1.4**

Table B1.4: Profile type with corrugation having wavelength (c) · height (h_{corr}) = 200×55, see **Figure B1.5**

Table B1.5: Profile type with corrugation having wavelength (c) · height (h_{corr}) = 381×140 (so-called SuperCor), see **Figure B1.6**

¹⁷ The sheet metal thickness is the thickness of the steel excluding any corrosion protection

If the values of c , h_{corr} , R , m_t and α are known, the area, moment of inertia and plastic section modulus can be calculated according to the equations

$$r = R + t / 2 \quad (\text{b1.b})$$

$$A / (\text{mm}^2 / \text{mm}) = (4\alpha r t + 2m_t t) / c \quad (\text{b1.c})$$

$$e = r \left(1 - \frac{\sin \alpha}{\alpha} \right) \quad (\text{b1.d})$$

$$I / (\text{mm}^4 / \text{mm}) = \left[r^3 t \left(\alpha + \frac{\sin 2\alpha}{2} - \frac{2\sin^2 \alpha}{\alpha} \right) + 4\alpha r t \left(\frac{h_{\text{corr}}}{2} - e \right)^2 + \frac{2}{12} \frac{t}{\sin \alpha} (m_t \sin \alpha)^3 \right] / c \quad (\text{b1.e})$$

$$Z / (\text{mm}^3 / \text{mm}) = \left[4\alpha r t \left(\frac{h_{\text{corr}}}{2} - e \right) + \frac{1}{2} \frac{t}{\sin \alpha} (m_t \sin \alpha)^2 \right] / c \quad (\text{b1.f})$$

The section modulus W and radius of gyration i are given by

$$W = \frac{2I}{h_{\text{corr}} + t} ; i = \sqrt{\frac{I}{A}} \quad (\text{b1.g})$$

Local buckling

The chosen corrugated profile must be checked with respect to the risk of local buckling. This can be done using the following relationship:

$$M_{\text{ucr}} = (1,429 - 0,156 \cdot \ln((m_t / t) \cdot (f_{\text{yk}} / 227)^{1/2})) \cdot M_{\text{u}} \quad (\text{b1.h})$$

where m_t is the corrugated profile's tangent length. The reduction has been proposed by *Cary (1987)*. A condition is that $M_{\text{u,cr}} \leq M_{\text{u}}$. Equation (b1.h) is illustrated in **Figure B1.2**, where the ratio $M_{\text{ucr}} / M_{\text{u}}$ is plotted as a function of sheet metal thickness for the profiles shown in **Figure B1.3** to **Figure B1.6**.

Cross corrugation

If so-called cross corrugation is used, the following reduction factor can be used – unless some other procedure is shown to be more correct – for the capacity of the corrugated profile *Atlantic Industries Ltd (1994)*:

$$M_{\text{ucr}} = 0,6 \cdot M_{\text{u}} \quad (\text{b1.i})$$

This reduction is valid for $t \geq 5,0$ mm. For thinner metal, the factor must be determined specifically.



Figure B1.1 Photo showing so called cross corrugation (from the Järpås full scale tests).

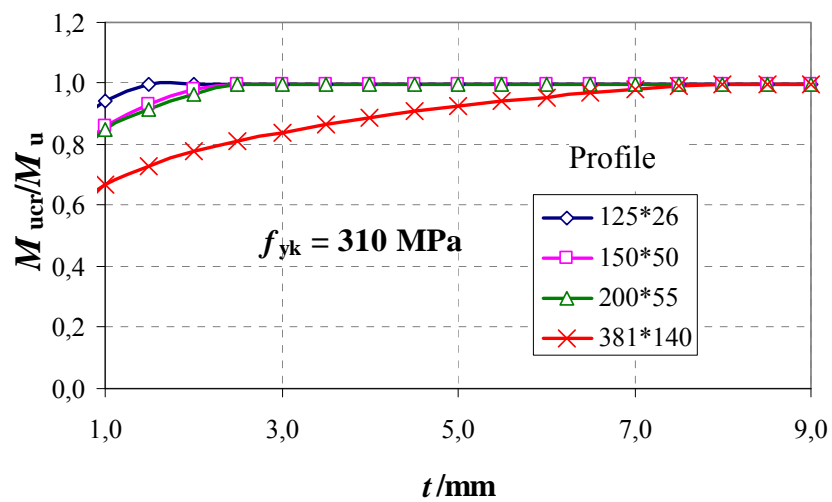

Figure B1.2 The ratio $M_{u,cr} / M_u$ as a function of sheet metal thickness for the profiles shown in Figures B1.3 – B1.6.

Profile data

Cross-sectional data for the different profiles are given in mm, mm²/mm, mm³/mm and mm⁴/mm per unit length of the pipe.

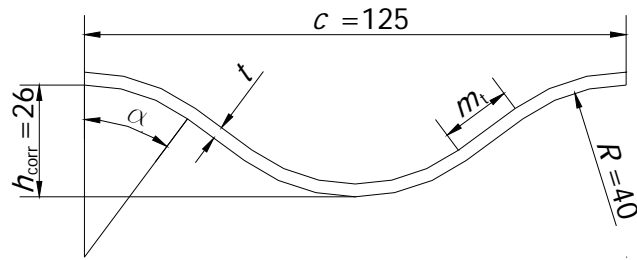

Figure B1.3 Dimensions of profile type 125×26. This profile is normally used in helically corrugated pipe arches.

t	A	I	W	Z	Z/W
mm	mm ² /mm	mm ⁴ /mm	mm ³ /mm	mm ³ /mm	-
1,5	1,66	143	10,4	13,9	1,34
2,0	2,21	191	13,6	18,5	1,36
2,5	2,77	239	16,8	23,2	1,38
3,0	3,32	288	19,9	27,9	1,41
3,5	3,88	337	22,8	32,6	1,43
4,0	4,43	386	25,7	37,4	1,45

Table B1.2 Profile 125×26: Area A (mm²/mm), moment of inertia I (mm⁴/mm), section modulus W (mm³/mm), plastic section modulus Z (mm³/mm) and Z/W for different sheet metal thicknesses, t (mm).

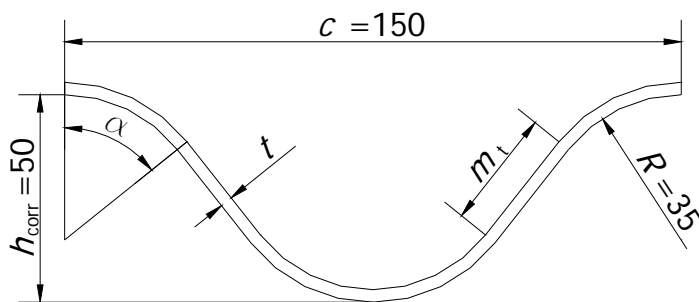

Figure B1.4 Dimensions of profile type 150×50.

t	A	I	W	Z	Z/W
mm	mm ² /mm	mm ⁴ /mm	mm ³ /mm	mm ³ /mm	-
2,00	2,51	777	29,9	39,6	1,32
3,00	3,77	1 173	44,3	59,7	1,35
4,00	5,04	1 573	58,3	79,9	1,37
5,00	6,30	1 978	71,9	100,4	1,40
6,00	7,57	2 387	85,2	121,0	1,42
7,00	8,85	2 801	98,3	141,9	1,44

Table B1.3 Profile 150×50: Area A (mm²/mm), moment of inertia I (mm⁴/mm), section modulus W (mm³/mm), plastic section modulus Z (mm³/mm) and Z/W for different sheet metal thicknesses, t (mm).

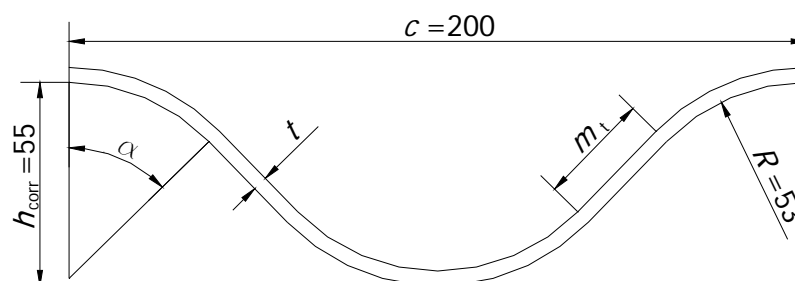

Figure B1.5 Dimensions of profile type 200×55.

t	A	I	W	Z	Z/W
mm	mm ² /mm	mm ⁴ /mm	mm ³ /mm	mm ³ /mm	-
2,00	2,36	898	31,5	41,4	1,31
3,00	3,54	1 353	46,7	62,3	1,34
4,00	4,73	1 811	61,4	83,3	1,36
5,00	5,92	2 273	75,8	104,5	1,38
6,00	7,10	2 739	89,8	125,8	1,40
7,00	8,29	3 208	103,5	147,3	1,42

Table B1.4 Profile 200×55: Area A (mm²/mm), moment of inertia I (mm⁴/mm), section modulus W (mm³/mm), plastic section modulus Z (mm³/mm) and Z/W for different sheet metal thicknesses, t (mm).

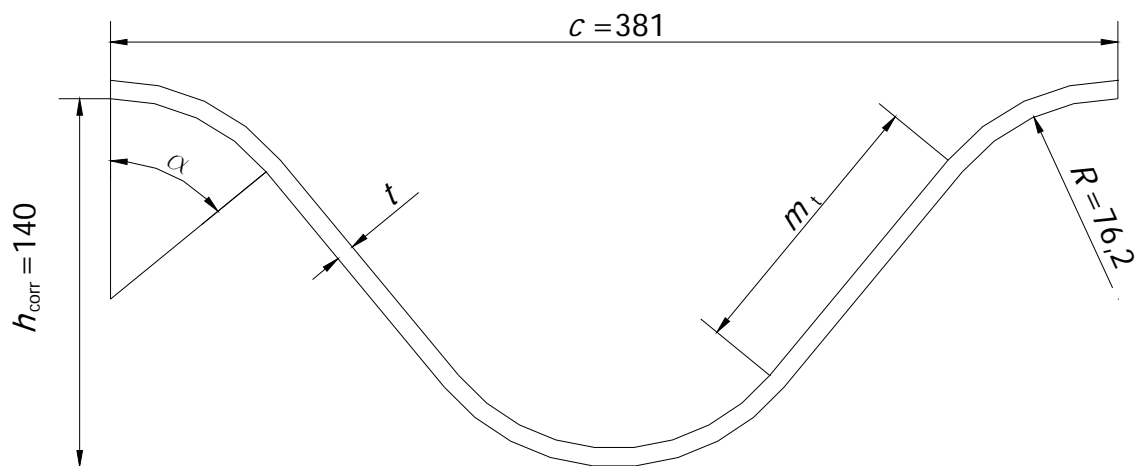

Figure B1.6 Dimensions of profile type 381×140 (SuperCor).

t	A	I	W	Z	Z/W
mm	mm ² /mm	mm ⁴ /mm	mm ³ /mm	mm ³ /mm	-
2,00	2,584	5 989	84,3	110,5	1,31
3,00	3,878	9 005	125,9	166,0	1,32
4,00	5,173	12 035	167,2	221,8	1,33
5,00	6,469	15 081	208,0	277,7	1,33
6,00	7,766	18 141	248,5	333,8	1,34
7,00	9,065	21 217	288,7	390,2	1,35

Table B1.5 Profile 381×140: Area A (mm²/mm), moment of inertia I (mm⁴/mm), section modulus W (mm³/mm), plastic section modulus Z (mm³/mm) and Z/W for different sheet metal thicknesses, t (mm).

Appendix 2 – Characteristic soil modulus

The design tangent modulus for the structural backfill can in this manual be determined by two different methods. Method A is a simplified method where the only input data required is the relative degree of compaction (RP). Method B is a more accurate method where more geotechnical input data are required. Method B generally yields a higher modulus value, but in return it requires a better knowledge of the properties of the surrounding soil. Note that the height of cover is used when calculating the soil modulus, not the effective height of cover.

Method A

Based on information regarding the type of material, degree of compaction and overburden pressure from the soil cover (expressed as a certain depth of cover of the soil material), the following equation can be used

$$E_{\text{soil,k}} = 1,3 \cdot 1,17^{(RP-95)} [1,25 \ln(h_c + H/2) + 5,6] \quad (\text{b2.a})$$

This equation is based on *Duncan (1979)*, and it is applicable to the soil materials classified as SP (= poorly graded sand), GP (= poorly graded gravel), SW (= well-graded sand) and GW (= well-graded gravel) according to the “Unified Soil Classification System”. According to Duncan, the equation gives conservative values of the tangent modulus because low values of the basic parameters (modulus number and stress coefficient) are chosen throughout. The results of calculations for different degrees of compaction and different cover depths are shown in **Figure B2.1**

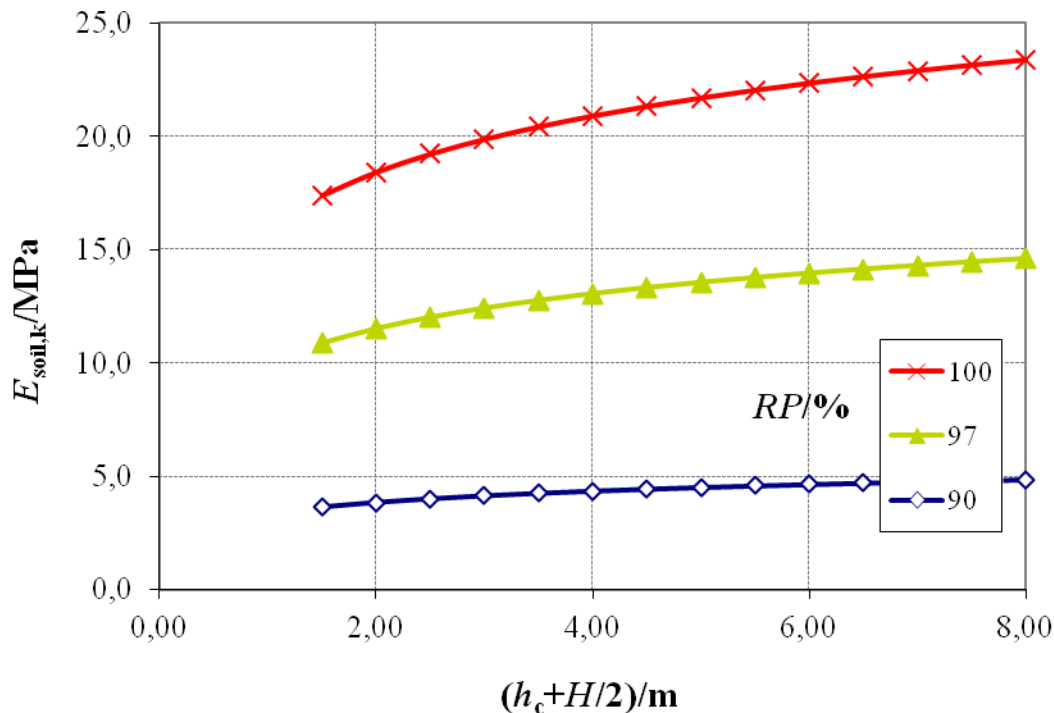

Figure B2.1 Relationship between characteristic tangent modulus and cover depth for different relative degrees of compaction according to the simplified method A assuming $H = 2,0 \text{ m}$.

The degree of compaction RP in Eq. (b2.a) is the standard Proctor value RP^{std} . For the materials used in the surrounding filling for culverts, the relationship between the Modified Proctor¹⁸ and the Standard Proctor is approximately given by: $RP^{\text{mod}} = RP^{\text{std}} - 5\%$.

Method B

Method B is based on a detailed investigation of the structural backfill material (within soil volume ②) where the following input data are required:

- Particle size distribution (d_{10} , d_{50} and d_{60}). The following limitations apply: $0,5 < d_{50} < 30$ and $2 < C_u < 30$.
- Degree of compaction $RP = 100 \cdot (\rho_{\text{surr}} / \rho_{\text{opt}})$ (dry density and maximum dry density) and
- Stress level in the surrounding fill calculated using the at rest earth pressure at a depth equal to the cover depth plus $H/2$.

If Method B is used, it is assumed that the chosen soil parameters are verified using control measurements in each case.

The tangent modulus is determined in the following stages:

The void ratio is calculated using the equation

$$e = \frac{\rho_s}{\rho} - 1; e_0 = \frac{\rho_s}{\rho_{\text{surr}}} - 1 \quad (\text{b2.b})$$

where ρ_s in this manual is set equal to 26 kN/m^3 .

The modulus ratio is calculated as

$$m = 282 \cdot C_u^{-0,77} \cdot e_0^{-2,83} \quad (\text{b2.c})$$

where e_0 is the void ratio and the uniformity coefficient C_u is calculated as

$$C_u = d_{60} / d_{10} \quad (\text{b2.d})$$

The stress exponent is calculated as

$$\beta = 0,29 \cdot \log\left(\frac{d_{50}}{0,01}\right) - 0,065 \cdot \log(C_u) \quad (\text{b2.e})$$

where the values of d_{50} is inserted in mm. The characteristic angle of internal friction of the structural backfill material (within soil volume ②) is calculated as

¹⁸ Proctor compaction, see EN 13286-2.

$$\varphi_k = 26^\circ + 10 \cdot (RP - 75) / 25 + 0,4 \cdot C_u + 1,6 \cdot 10^{\log(d_{50})} \quad (\text{b2.f})$$

In the above equation the relationship between the relative density and degree of compaction is assumed to follow the relationship $I_D = (RP - 75) / 25$ with the degree of compaction determined according to the Standard Proctor method. See also *Larsson (1989)*.

The tangent modulus is calculated according to:

$$E_{\text{soil,k}} = \left[1 - \frac{R_f \cdot (1 - \sin \varphi_k) \cdot (\sigma_1 - \sigma_3)}{2 \cdot \sigma_3 \cdot \sin \varphi_k} \right]^2 k_v \cdot m \cdot p_a \cdot \left(\frac{\sigma_3}{p_a} \right)^{1-\beta} \quad (\text{b2.g})$$

$$k_v = \frac{1 - \nu - 2\nu^2}{1 - \nu} = \frac{\sin \varphi_k (3 - 2 \sin \varphi_k)}{2 - \sin \varphi_k} \quad (\text{b2.h})$$

After insertion of $R_f = 0,7$, $p_a = 100 \text{ kPa}$ and the stress situation equivalent to the at rest earth pressure at the level immediately under the quarter-points of the culvert, we obtain

$$E_{\text{soil,k}} = 0,42 \cdot m \cdot 100 \text{ kPa} \cdot k_v \left(\frac{(1 - \sin \varphi_k) \cdot \rho_{h_c+H/2} \cdot S_{\text{ar}}(h_c + H/2)}{100 \text{ kPa}} \right)^{1-\beta} \quad (\text{b2.i})$$

The values obtained by the methods A and B are shown in **Figure B2.2** for sub base soil used for backfilling of bridges in Sweden, compare **Table B2.1**. The requirements with regard to different materials for bridge backfilling soils for Swedish conditions of culverts are given in *TK Geo 11*¹⁹.

Fill material	Optimum unit density (N/m ³)	Unit density (kN/m ³)	Angle of friction (°)	Static soil pressure, K_0	C_u , (d ₆₀ /d ₁₀)	d_{50} (mm)
Crushed rock	19,6	19	45	0,29	15	70
Sub base material	20,6	20	40	0,36	10	20
Base course material	21,7	21	43	0,32	15	10

Table B2.1 Soil parameters for typical backfilling materials according to *TK Geo 11*.

¹⁹ For other soils and compaction values, local conditions should be used.

Fill material	e	m	β	k_v	$E_{\text{soil},k}$ MPa
Crushed rock	0,37	591	1,04	0,87	23
Sub base material	0,30	1 445	0,89	0,81	40
Base course material	0,24	2 034	0,79	0,85	47

Table B2.2 Calculated soil parameters for typical filling materials according to TK Geo 11, (see Table B2.1). $E_{\text{soil},k}$ is calculated for a circular culvert with $H = 2,0$ m and $h_c = 1,0$ m.

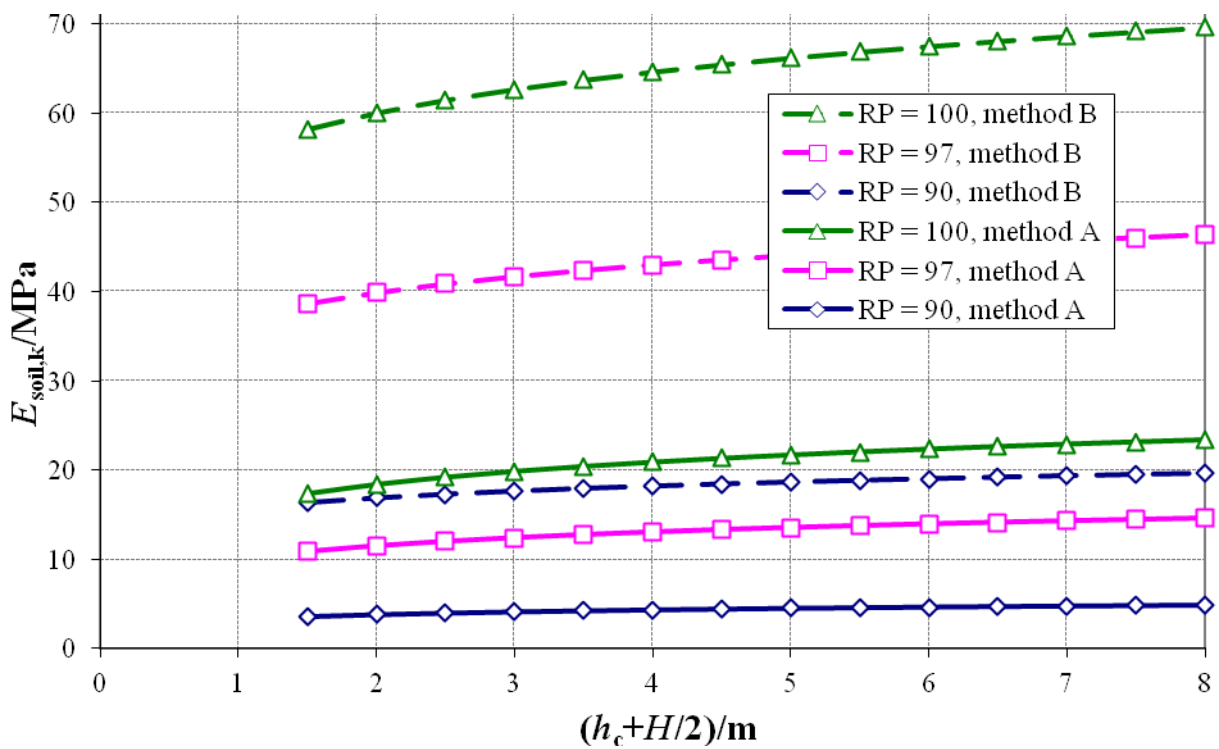

Figure B2.2 Comparison between the characteristic tangent modulus calculated using the simplified (full lines) and using the more accurate method (dashed lines). For the sake of comparison, it has been assumed that $H = 2$ m, $C_u = 10$ and $d_{50} = 20$. The arching factor S_{ar} is set equal to 1,0.

Appendix 3 – Calculation of the upward deflection of the crown during back-filling

During the back-filling process, soil pressures arise that act against the side of the pipe and result in an upward deflection of the crown. This leads to a reduction in the cover depth for a given value of the distance between the bottom of the pipe and the level of the road surface. This is one of the conditions included in the design principles and it is not a problem in itself, apart from the fact that the effective cover depth is reduced. If the cover depth is low, this will affect the traffic load effects. We take this phenomenon into account by introducing a reduced cover depth according to the expression

$$h_{c,\text{red}} = h_c - \delta_{\text{crown}} \quad (\text{b3.a; 4.a})$$

In **Section 4.2**, an approximate value was given for the crown rise. A more refined analysis method gives

$$\frac{\delta_{\text{crown}}}{D} = \frac{\rho_{\text{surr}} D}{E_{\text{soil},k}} f_h(H/D, \lambda_f) = 0,013 \frac{\rho_{\text{surr}} D}{E_{\text{soil},k}} \left(\frac{H}{D}\right)^{2,8} \lambda_f^{0,56-0,2 \ln\left(\frac{H}{D}\right)} \quad (\text{b3.b})$$

The parameter f_h is shown for some actual values in **Figure B3.1**.

In Eq. (b3.b), it is important that $E_{\text{soil},k}$ and not $E_{\text{soil},d}$ is used. **Eq. (b3.b)** is valid only for closed profiles, i.e. profiles where the pipe can simultaneously be compressed horizontally when the crown rises. In the case of culverts with foundation slabs, the effect of the pipe's vertical deflection can be neglected as long as the sheet metal wall is connected to the foundation slab vertically or with an outward slope. In the case of profiles with an inward sloping sheet metal wall connecting to the foundation slab, the rise of the crown can be calculated as one quarter of the value given by **Eq. (b3.b)**.

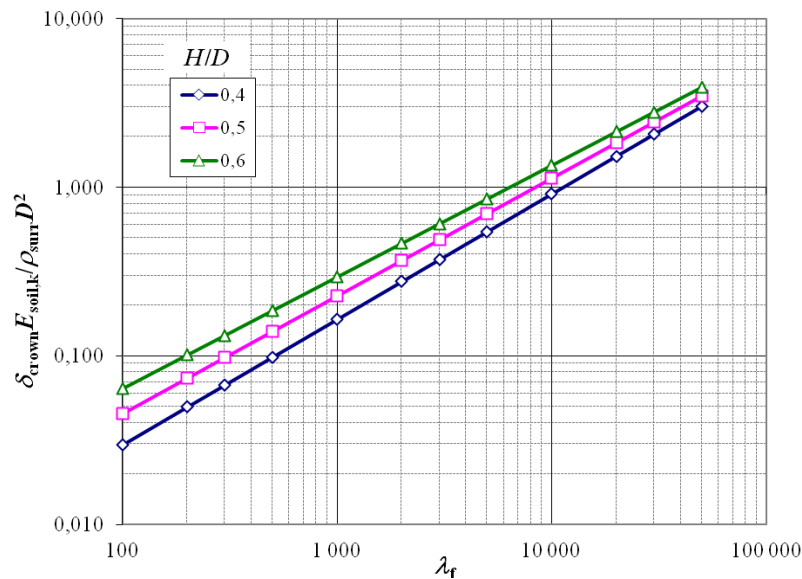

Figure B3.1 Diagram for determining how much the crown rises during the backfilling operation.

Appendix 4 – Live load distribution

According to Boussinesq (1883), the stress distribution beneath a point load P can be approximately calculated (see **Section 4.3.5**, Eq. (4.i)) using the expression

$$\sigma_v = \frac{3 \cdot P \cdot h_c^3}{2\pi \cdot s^5} \quad (\text{b4.a})$$

where P is the point load, h_c is the depth below the surface of the ground, and s is the distance from the point load to the point where the vertical pressure is to be calculated. In the design of a culvert, the vertical pressure shall be converted to an equivalent line load on the surface using the equation

$$p_{\text{traffic}} = \frac{\sigma_v \pi h_c}{2} \quad (\text{b4.b})$$

The two equations presented above will be used to develop some diagrams, both in this appendix and in **Appendix 6** and **7**.

When looking at a general case, see **Figure B4.1**, the pressure at a point (x, y) for a depth h_c can be calculated using the Eq. (b4.c) which is basically the same equation as Eq. (b4.a).

$$\sigma_v = \frac{P}{2} \frac{3}{2\pi} h_c^3 \sum_{i=1}^6 \frac{1}{s_i^5} \quad (\text{b4.c})$$

Where s_i is calculated as the sloping distance between the point where the vertical pressure is to be calculated and the centre of gravity of the respective loads.

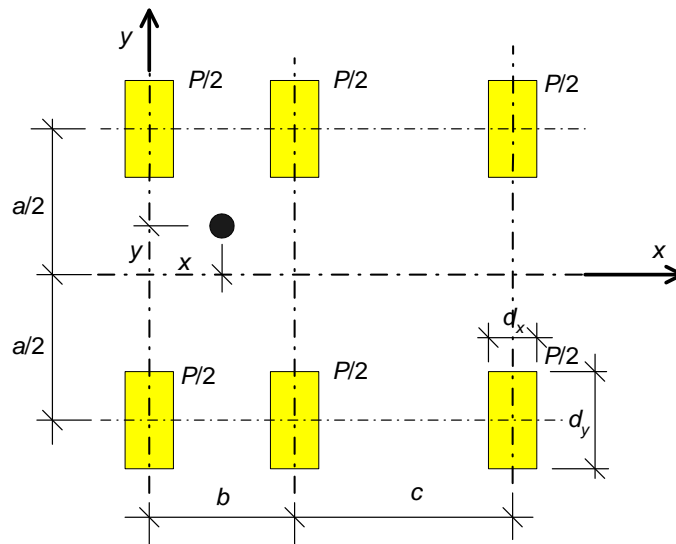

Figure B4.1 An example of a load group for which the pressure at a certain point (x, y) , at a depth h_c , is to be calculated.

In the same way, the formula above is implemented on a load case taken from *EN 1991-2*, see **Figure B4.2**.

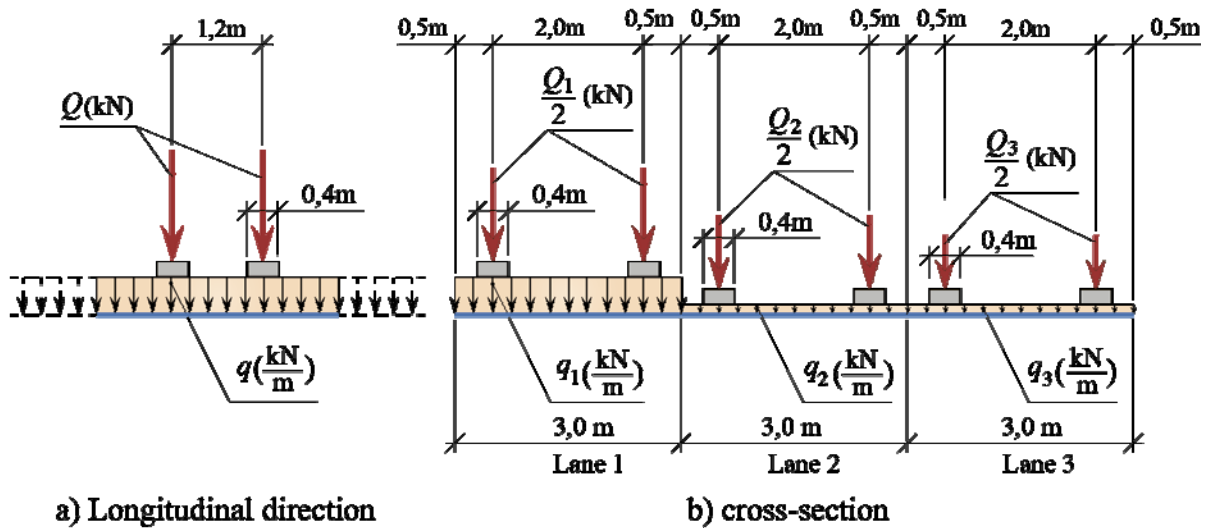

Figure B4.2 Load group LM1 according to Eurocode.

Let us now study what happens when we calculate the vertical pressure for different cover depths with the values for Load Model 1, LM1, given in *EN 1991-2*. The calculation is based on the following criteria:

1. Load values, wheel size and other dimensions are assumed as per *EN 1991-2*. The calculation is based on three lanes of traffic.
2. Consideration is given to the area over which the wheel load is distributed. This is achieved by representing each wheel load by point loads, where each wheel load is divided into 49 loading points. The division is represented in the form of a 7 by 7 matrix as shown in **Figure B4.3**.
3. The value of the uniformly distributed load q is set to zero.

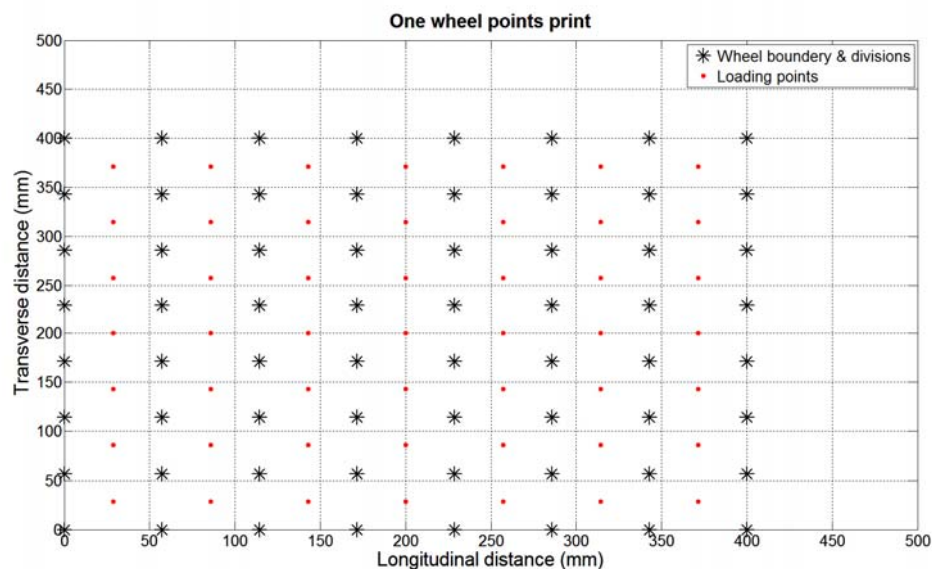

Figure B4.3 Matrix of loading points representing one wheel for LM1.

When studying the vertical pressure for different cover depths, see **Figure B4.4** to **Figure B4.6**, it can be seen the effect of load concentration under wheels for small covers, while this effect gradually decreases for larger cover depths.

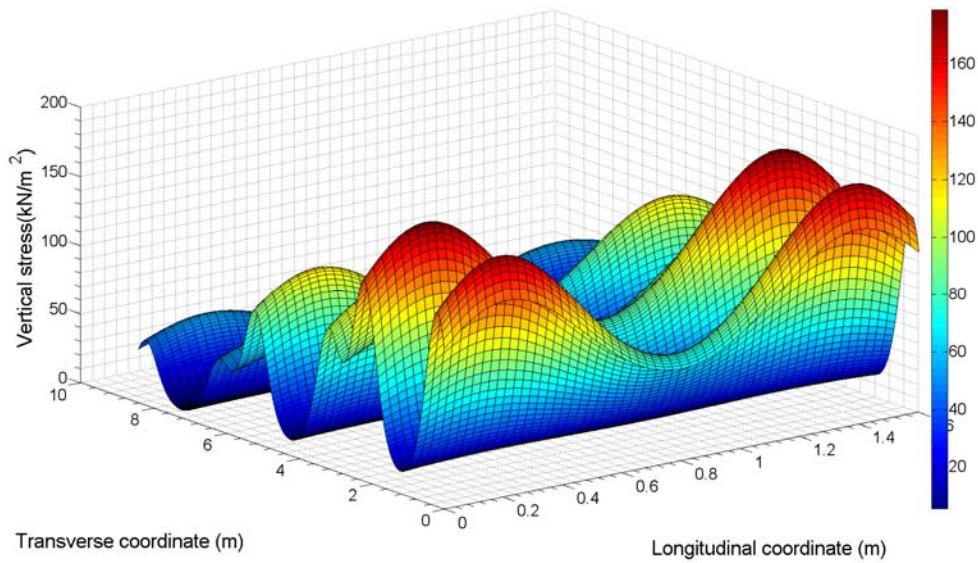

Figure B4.4 Vertical stress for Load Model, LM1, at a depth of 0,6 m.

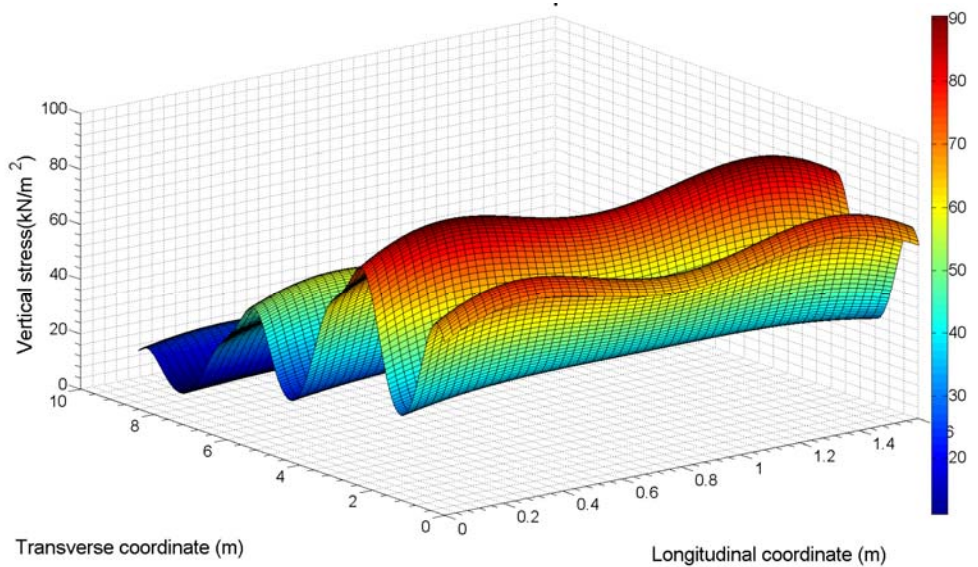

Figure B4.5 Vertical stress for Load Model, LM1, at a depth of 1,0 m.

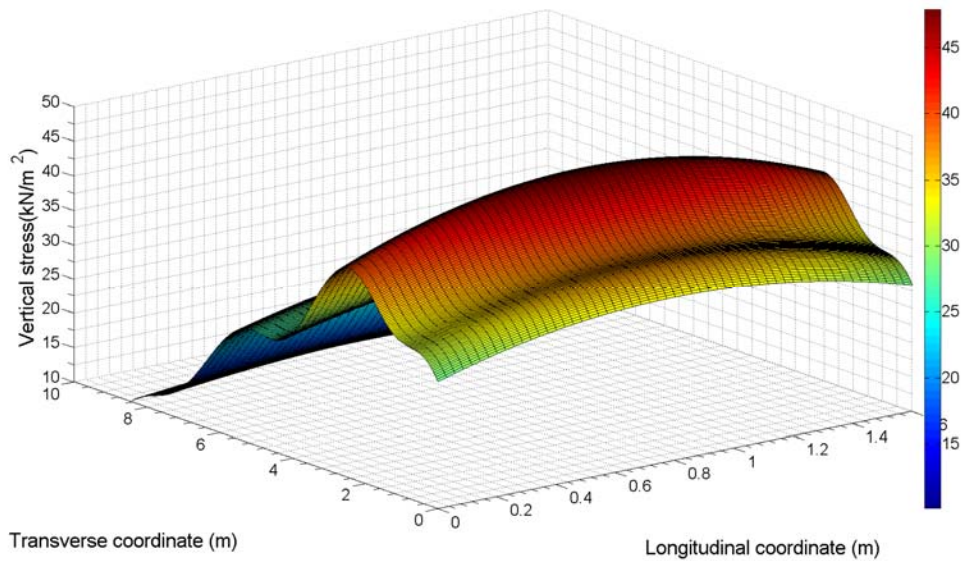

Figure B4.6 Vertical stress for Load Model, LM1, at a depth of 2,0 m.

The consideration of wheel loads as distributed loads has been taken into account for the figures above. However, if the distribution of the loads is not taken into consideration, both the vertical pressure and the equivalent line load are amplified somewhat, as shown in **Figure B4.7**. As expected, the load distribution has very little effect in the case of large cover depth.

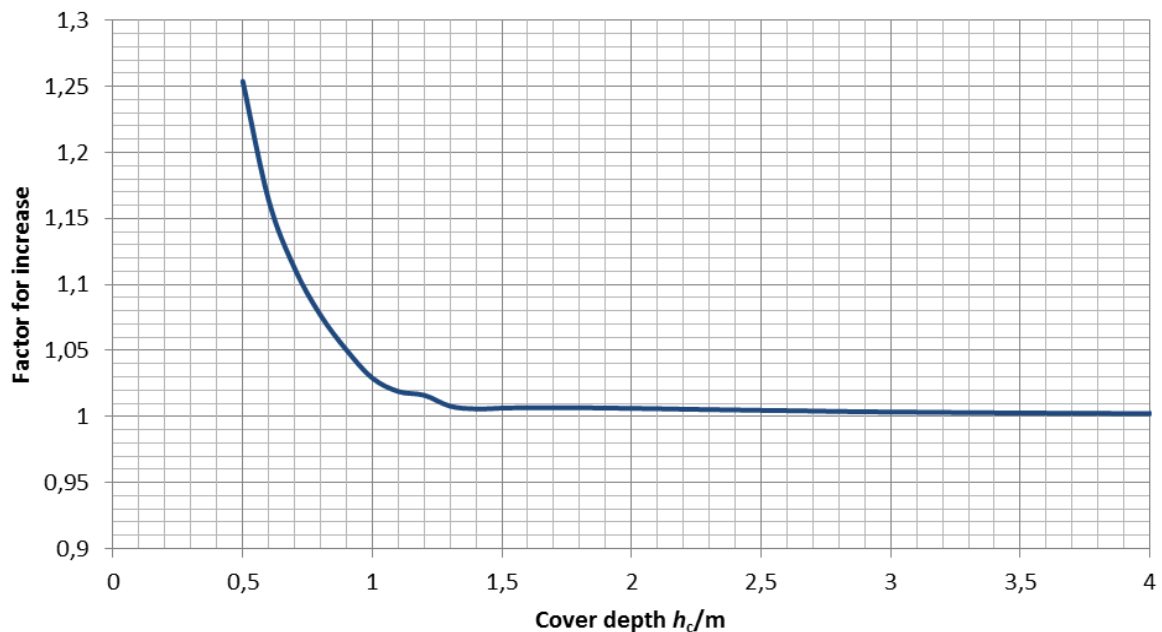

Figure B4.7 Increase of equivalent line load for small depth of cover based on LM1, when the effect of the distribution of the load is neglected.

The influence of adjacent lanes of traffic is seen in **Figure B4.8**, where it is evident the additional pressure emerging from adjacent lanes is more pronounced at larger height of cover. In **Figure B4.9** and **Figure B4.10**, both the ordinary LM1 and the local verification load case according to *EN 1991-2, 4.3.2(5)*, are shown.

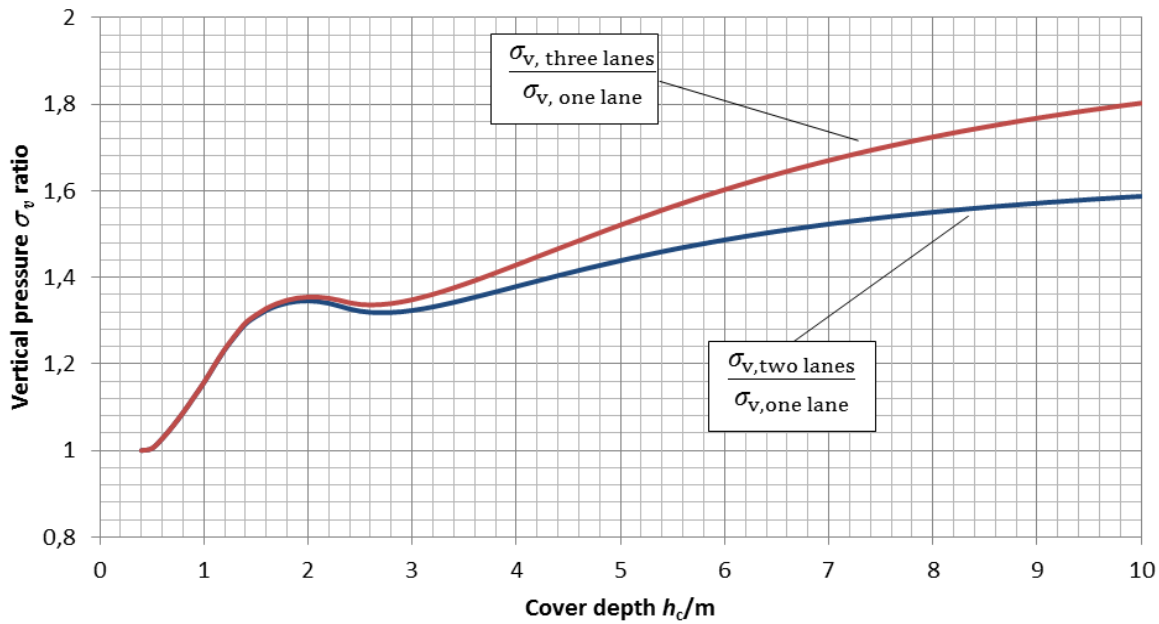

Figure B4.8 Influence on vertical pressure of adjacent lanes for LM1 using $\alpha_Q = 1,0$.

The equivalent line loads for LM1 and LM2 pertaining to EN 1991-2 are presented in **Figure B4.9**, **Figure B4.10** and **Figure B4.11**. Design curves are also shown with α - and β -values according to the Swedish application, TRVFS 2011:12 of the Eurocode. It is important to highlight that these curves are presumed to be generated by finding a point location where maximum stress occurs. This is nearly achieved by dividing the area into many calculation points whereas stresses are evaluated and maximum stresses are closely captured.

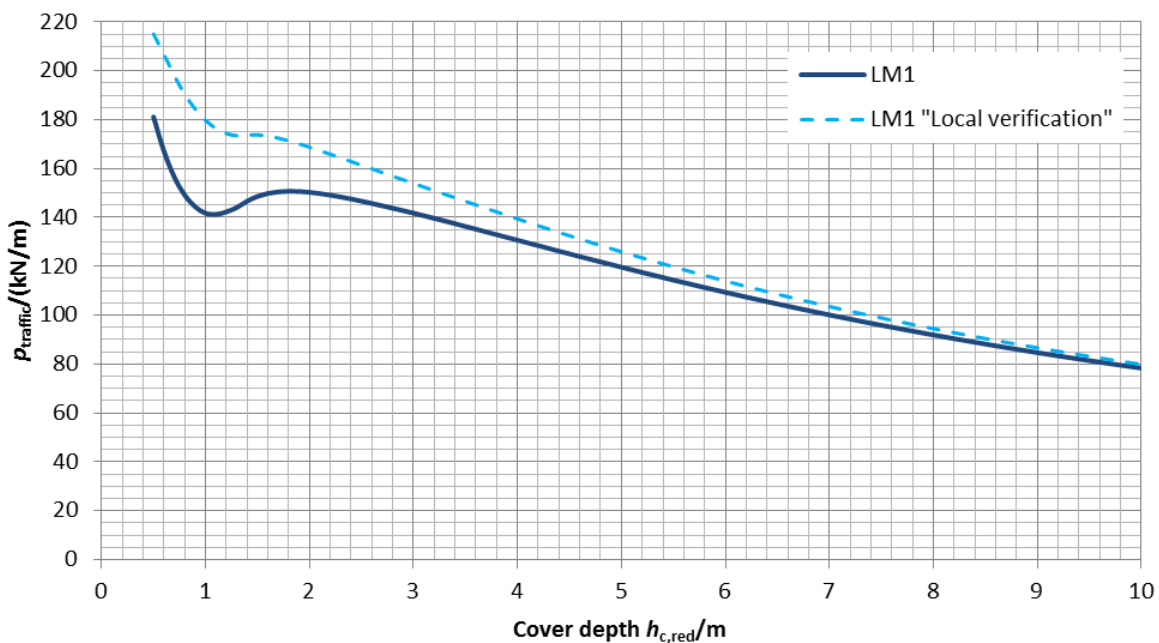

Figure B4.9 Equivalent line load for LM1²⁰ according to EN 1991-2 using $\alpha_Q = 1,0$.

²⁰ The load case LM1 “local verification” EN 1991-2, 4.3.2(5), might be considered depending on the road and traffic situation at the bridge site.

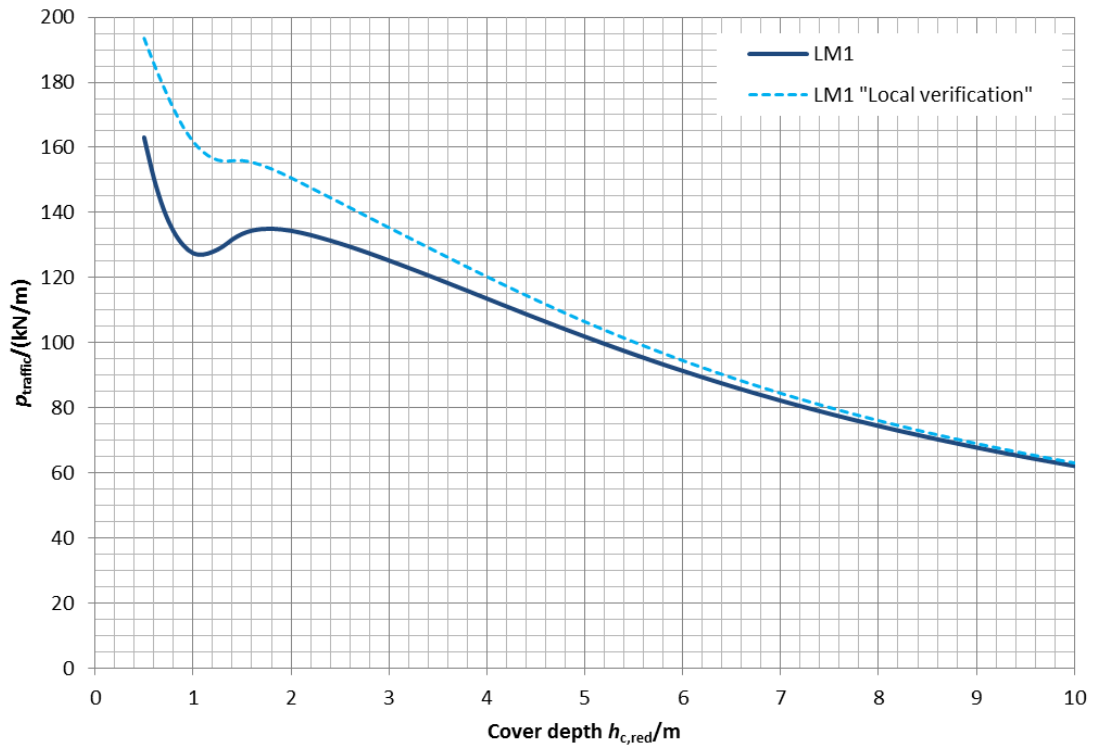

Figure B4.10 Equivalent line load for LM1²⁰ according to EN 1991-2 using $\alpha_{Q1} = 0,9$, $\alpha_{Q2} = 0,9$, $\alpha_{Q3} = 0$.

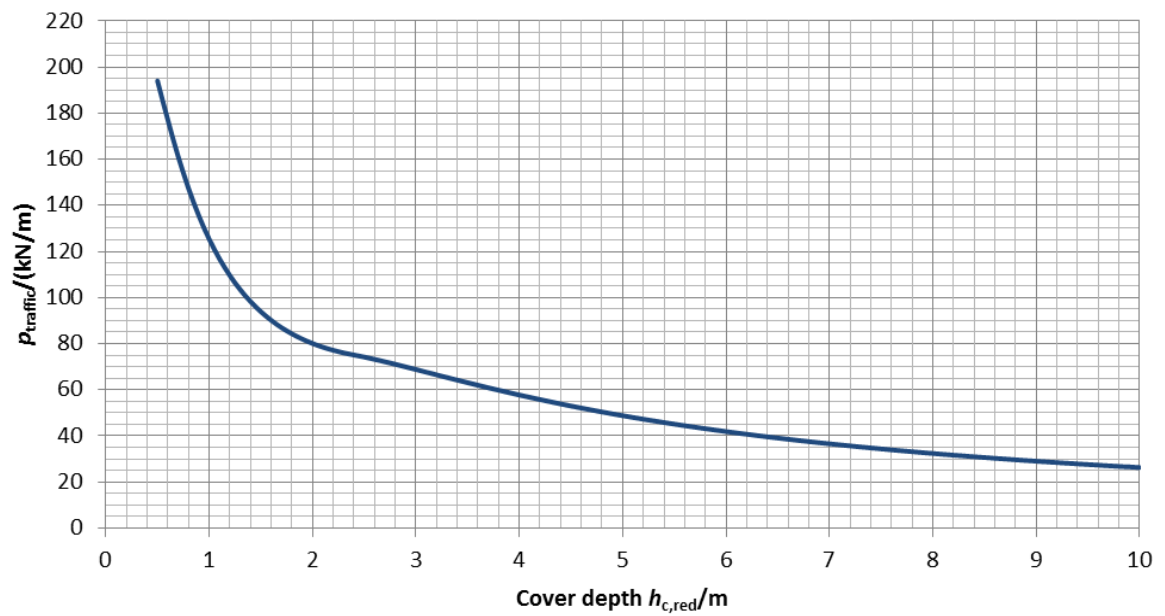

Figure B4.11 Equivalent line load for LM2 according to EN 1991-2 using $\beta_Q = \alpha_{Q1} = 0,9$.

Appendix 5 – Second-order theory

For a circular pipe ($R = R_t$) which is embedded in soil that extends for a long distance outside the pipe, the buckling force, under simplified ideal conditions, can be calculated from the expression:

$$N_{cr,el} = 1,2 \sqrt{\frac{E_{soil,d} \cdot (EI)_{steel}}{R}} \quad (b5.a)$$

where

$E_{soil,d}$ the design tangent modulus for the soil, kN/m^2

$(EI)_{steel}$ the stiffness of the pipe per unit length, kNm

$N_{cr,el}$ buckling load per unit length of pipe, kN/m .

Based on *Klöppel & Glock (1970)* and *Abdel-Sayed (1978)* the following adjustment of Eq. (b5.a) can be derived

$$N_{cr,el} = \frac{3\xi}{\mu} \sqrt{\frac{E_{soil,d} \cdot (EI)_{steel}}{R_t}} \quad (b5.b)$$

In order to take into consideration the insufficient lateral support from the soil when the cover depth is small, the parameters in equation (b5.b) can be calculated using the following equations, which are expressed in the form of a reduced tangent modulus:

$$\frac{E_{soil,d,red}}{E_{soil,d}} = \eta_s = 1 - \left(\frac{1}{1 + \kappa_2} \right)^2 \quad (b5.c)$$

$$\mu = \left(1,22 + 1,95 \left(\frac{(EI)_s}{\eta_s \cdot E_{soil,d} \cdot R_t^3} \right)^{0,25} \right)^2 \frac{1}{\sqrt{\eta_s}} \quad (b5.d)$$

In the special case when $R_t = D/2$, Eq. (b5.d) can be written:

$$\mu = \left(1,22 + 1,95 \left(\frac{8}{\eta_s \cdot \lambda_f} \right)^{0,25} \right)^2 \frac{1}{\sqrt{\eta_s}} \quad (b5.d')$$

$$\xi = \sqrt{\kappa_2} \leq 1,0 \quad (b5.e)$$

$$\kappa_2 = h_c / R_t \quad (b5.f)$$

It is here evident that the most important parameter is $\kappa_2 = h_c / R_t$. The result of the calculation is shown in **Figure B5.1** for the case when $R_t = D/2$.

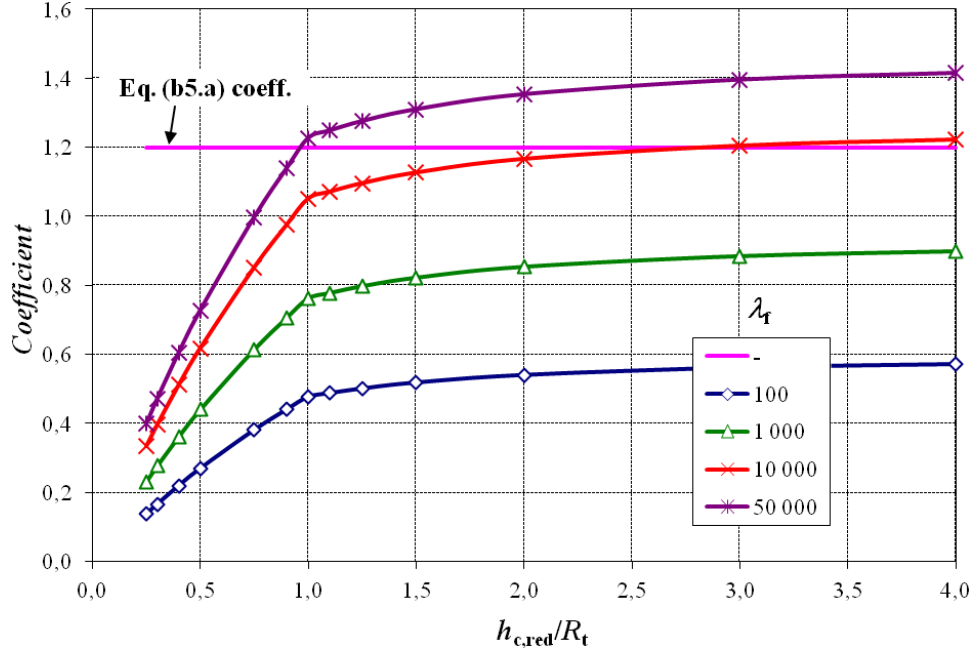

Figure B5.1 Buckling load shown in the form $N_{cr,el} = coefficient \cdot \sqrt{\frac{E_{soil,d} \cdot (EI)_{steel}}{R}}$ as a function of the cover depth ratio $h_{c,red} / R_t$ when $R_t = D/2$.

The critical load N_{cr} may be calculated as $N_{cr,el}$ provided that

$$\left(\frac{R_{cr}}{R_t} \right)^2 = \frac{N_{cr,el}}{N_u} \leq 0,5 \quad (b5.g)$$

where $N_u = f_{yd} \cdot A$.

If $\left(\frac{R_{cr}}{R_t} \right)^2 = \frac{N_{cr,el}}{N_u} > 0,5$, N_{cr} is reduced using the formula:

$$\frac{N_{cr}}{N_u} = \omega = \left(1 - \frac{1}{4} \frac{N_u}{N_{cr,el}} \right) \quad (b5.h)$$

Equation (b5.h) is shown graphically in **Figure B5.2**.

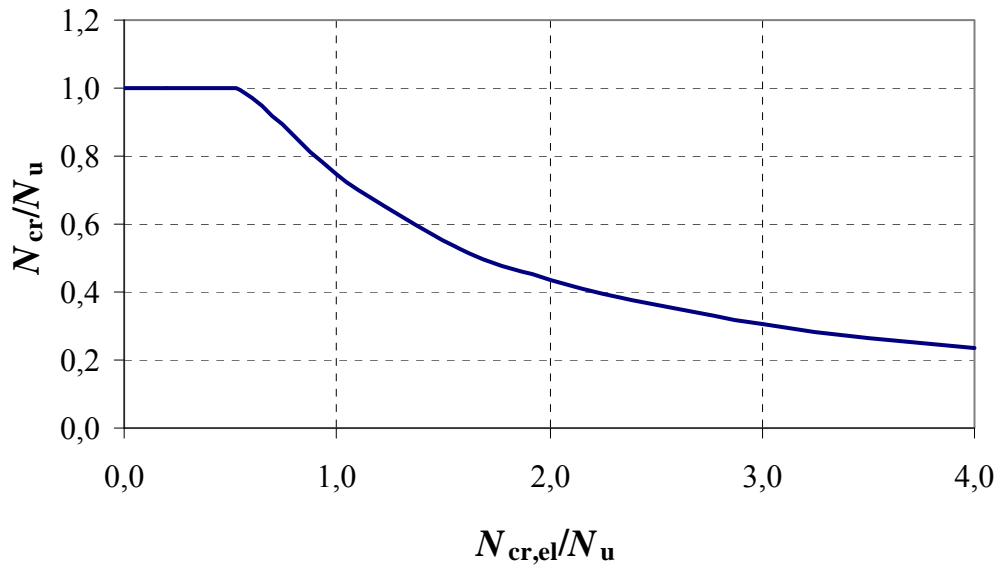

Figure B5.2 *Reduction factor of the buckling load when the elastic (Euler) buckling load is large.*

Appendix 6 – Railway load

If a culvert is to be placed under a railway, see **Figure B6.1**, then consideration must be given to the construction and maintenance of the track, i.e. ballast, sleepers and rails. The usual ballast thickness in Sweden, h_b , is 0,5 m and in this manual it is assumed that the depth of cover, h_c , shall be at least 0,5 m. In the case of a railway, the thickness h_c of the covering layer is calculated from the base of the sleepers as shown in the figure. Since the culvert including the structural backfill is usually constructed first, this may mean that the cover associated with the culvert has a thickness of only 0,2 m. A check must be made to ensure that the culvert without the ballast can support the machines that will be used to place the ballast. A much larger cover depth may of course often be required for the actual loads.

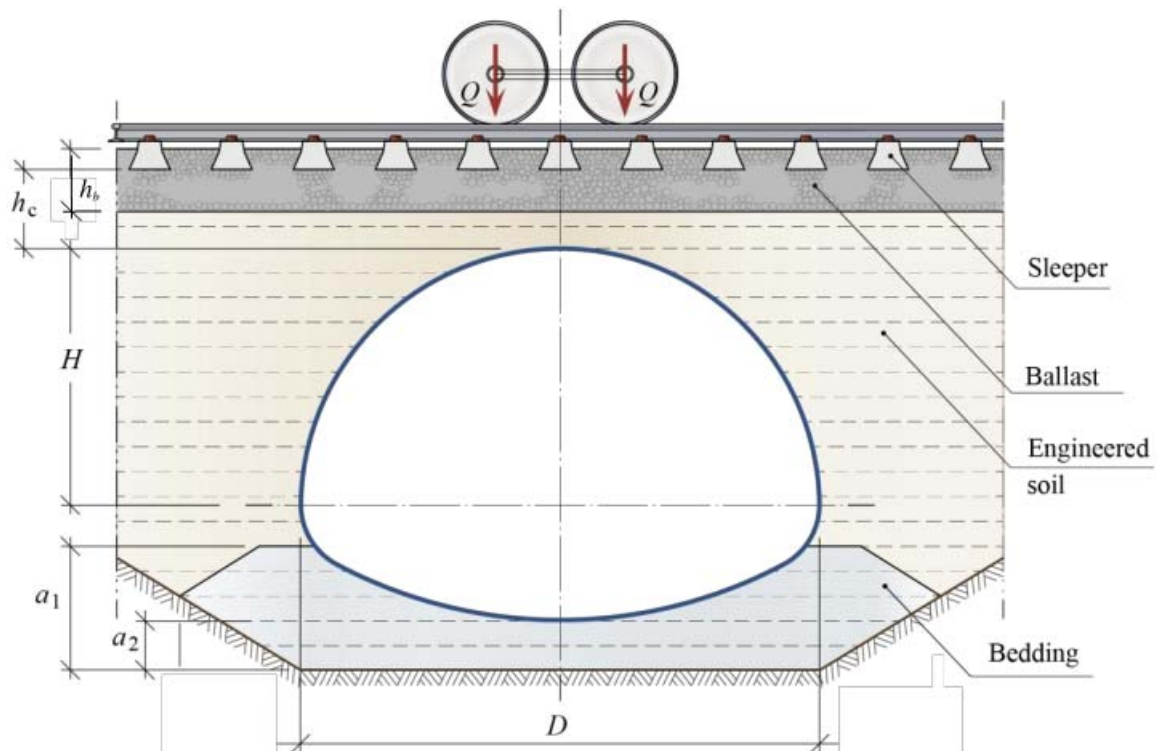

Figure B6.1 Cross-section through a culvert under a railway.

For design purposes, the same principles are employed as for the road traffic loads, but with a number of conditions that are special for railways, as indicated in *EN 1991-2*. When calculating the bending moment in the culvert wall, only the axle loads indicated in *EN 1991-2*, 6.3.2 are considered²¹ and they are distributed over the sleepers according to the principles given in *EN 1991-2*, 6.3.6.1. The corresponding equivalent line load is shown in **Figure B6.3**. The load pattern used has the same form as the UIC 71 load (Load model 71), but with axle loads of 330 kN instead of 250 kN. Since the method used is based on the theory of elasticity the equivalent line loads can be reduced or increased in the same proportion to the relation between the axle loads.

²¹ For culverts with large span ($D > \sim 13$ m), the moments due to the evenly distributed loads should also be included in the analysis.

The influence of an adjacent track at a centre distance of 4,5 m can be calculated in the same manner and the combined effect is also shown in **Figure B6.3**. It may be noted that the equivalent line load calculated in this manner is often less than the comparable load for a road. This is because the distribution of the loads through the rail and the sleepers is more efficient, even though the total loads for a railway are often larger than those for a road.

The corresponding normal force is calculated from the point loads which are spread according to the simplified 2:1-principle through the height of cover. The vertical pressure, $p_{v,traffic,k}$, at the crown level is used to calculate the normal force

$$N_{traffic,k} = p_{v,traffic,k} \cdot R_t \tag{b6.a}$$

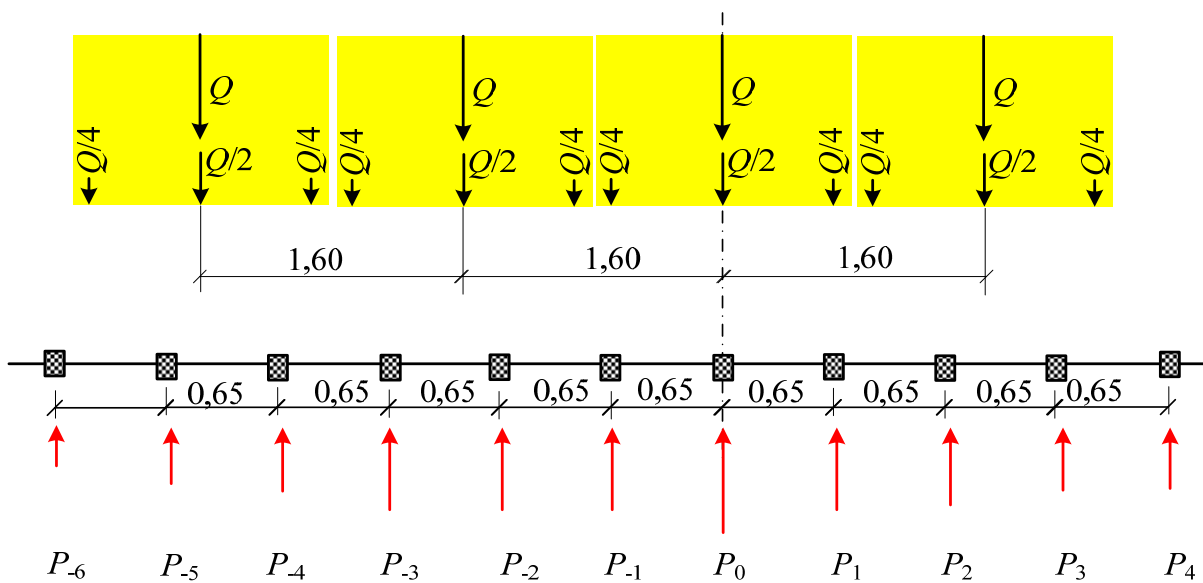

Figure B6.2 Axle loads (Q) from a train are assumed in EN 1991-2 to consist of 4 axle loads separated by distances of 1,6 m. These loads are assumed to be distributed over three sleepers with 50% of the axle load at the middle sleeper as shown in the figure. The loads under the sleepers down to the underside of the ballast are distributed as indicated in EN 1991-2.

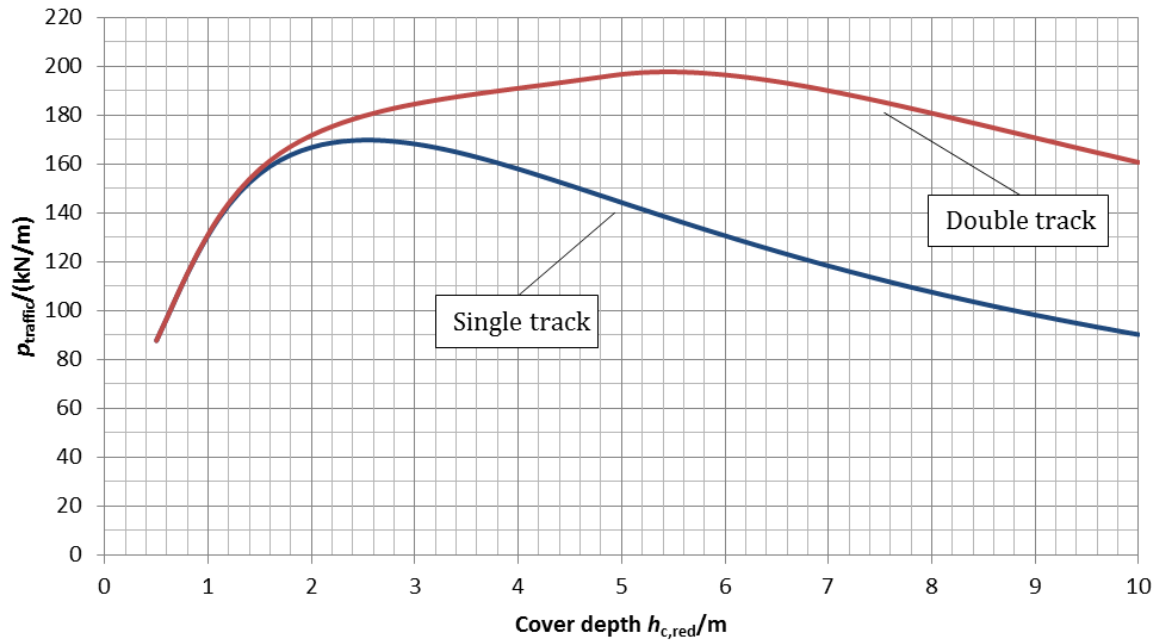

Figure B6.3 *Equivalent line load for single and double railway tracks according to the principles applied in this manual, for a culvert under a railway and for axle loads of 330 kN.*

The above diagrams can be also represented by set of equations as shown in **Table B6.1** below.

Load case	$h_{c,red}$ (m)	$p_{traffic}$ (kN/m)
Single track	$0,5 \leq h_{c,red} < 10,0$	$240,7 \cdot e^{(-0,1 \cdot h_{c,red})} - 243 \cdot e^{(-1,04 \cdot h_{c,red})}$
Double track	$0,5 \leq h_{c,red} < 10,0$	$284 \cdot e^{(-0,05 \cdot h_{c,red})} - 227,7 \cdot e^{(-0,48 \cdot h_{c,red})}$

Table B6.1 *Expressions for equivalent line loads in Figure B6.3.*

It is suggested that the value of L_{ϕ} for calculation of the dynamic amplification shall be twice the culvert span D , i.e. $L_{\phi} = 2 \cdot D$. It is further stated in **Section 3.5** that the live load dynamic amplification may be reduced for larger cover depths.

It is considered that the above interpretation of the loads and the dynamic amplification factor, in combination with the proposed calculation model, yields conservative results.

Appendix 7 – Checking the structural capacity of existing SSCB structures

B7.1 General

The general principles used for design of new SSCB can in principle be used even for existing SSCB, however some modification need to be observed.

B7.2 Design plate thickness

Due to corrosion, typically for structures used for conveying water under roads and railways, the plate thickness might be reduced.

The principles given in **Section 5.4.2** may be applied to check the capacity of the culvert below the springline using a reduced plate thickness because of corrosion. For corroded parts above the springline special investigation of the capacity should be performed.

The plate thickness used in the verification should be the smallest average thickness measured on one meter in the direction of the structure.

Observe that there must not be any local holes due to corrosion that can cause the backfill to erode and thus reducing the stabilizing forces from the soil.

B7.3 Cold forming effect on steel yield strength

Based on the principles in the Eurocode an increase in the steel yield strength, as a result of the cold forming when corrugating the steel plates, may be applied. Cold forming effects, calculated using the equation below, may be used for corrugations 150×50 mm and 200×55 mm (or for corrugations with similar size) and should be taken as an average value for the full steel section.

The increased average yield strength f_{ya} may be determined using Eq. (b7.a) below developed by *Lind and Schroff (1975)* and used as basis for *EN 1993-1-3*.

$$f_{ya} = f_{yb} + 5D_A(f_u - f_{yb})/W^* \quad (\text{b7.a})$$

Where f_{ya} , f_{yb} and f_u are the same notations as *EN 1993-1-3*, while D_A is equivalent to n in the same EN standard.

W^* is the ratio of centerline length of a flange cross-section of a member in bending, or of the entire cross section of a tensile or compressive member, to the design core thickness (w/t). In the case of used corrugation, w can be the typical length of section constituting two full arcs and two straight lines, see **Figure B7.1**.

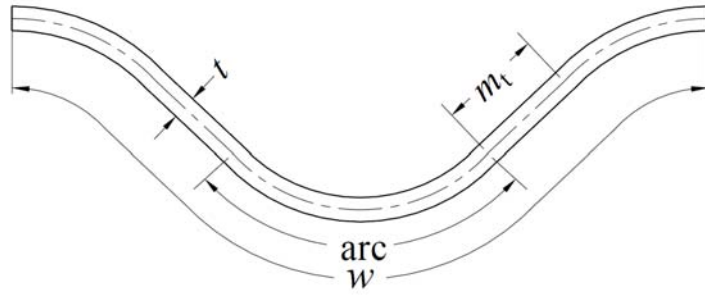

Figure B7.1 A typical centerline length w of section constituting two full arcs and two straight lines.

Using Eq. (b7.a) **Figure B7.2** and **Figure B7.3** below show some results for common steel grades and for corrugations 150×50 mm and 200×55 mm respectively.

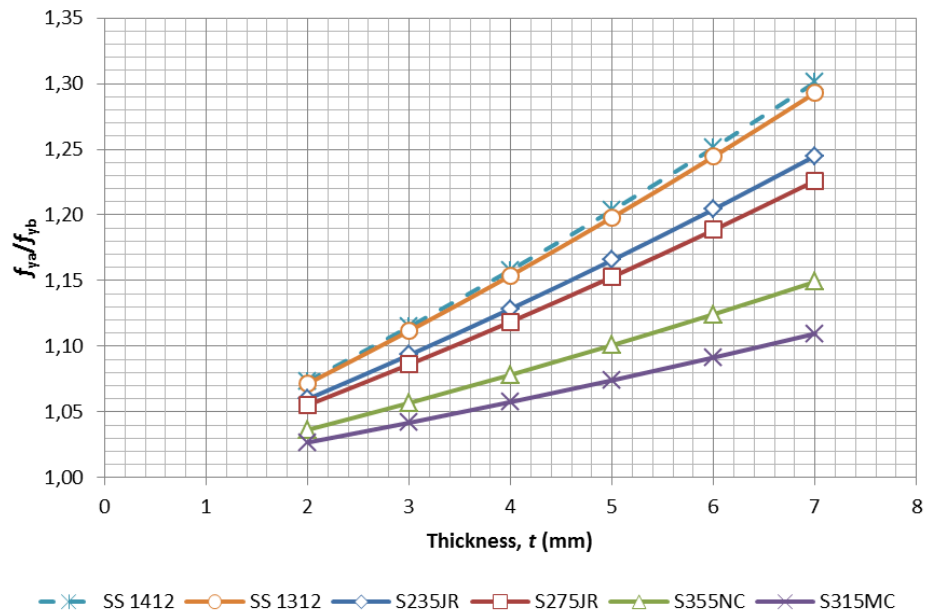

Figure B7.2 Average yield strength f_{ya} to basic yield strength f_{yb} for common steel types estimated for corrugation type 150×50 mm.

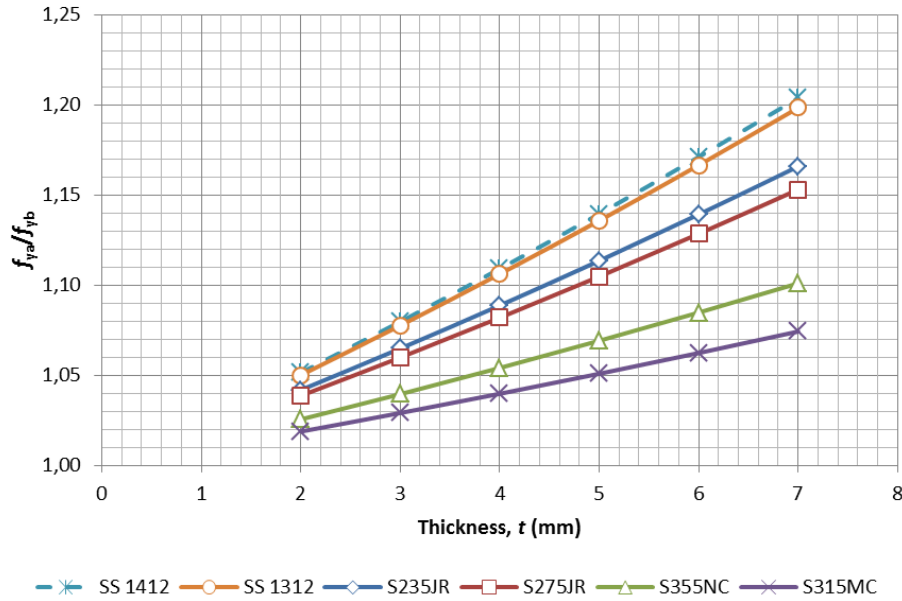

Figure B7.3 Average yield strength f_{ya} to basic yield strength f_{yb} for common steel types estimated for corrugation type 200×55 mm.

The maximum allowed yield strength used in the evaluation of an existing SSCB shall fulfil the requirement $f_{uk} / f_{ya,k} \geq 1,20$.

B7.4 Very small height of cover

For analysis of existing structures a minimum height of cover 0,25 m, may be used. For heights of cover smaller than 0,5 m a load concentration factor should be applied according to Eq. (b7.b)

$$p_{\text{traffic,mod}} = f_7 \cdot p_{\text{traffic}} \quad (\text{b7.b})$$

Where p_{traffic} is calculated according to Appendix 4 and

$$f_7 = 16 \cdot (h_c - 0,5)^2 + 1 ; 0,25 \leq h_c / \text{m} \leq 0,5 \quad (\text{b7.c})$$

SSCB are sensitive for the height of cover, and it thus recommended that different precautions should be applied for smaller heights of cover than 0,4 m or if there are uncertainties about soil stiffness or other important design parameters.

It is recommended that, for structures having a height of cover of less than 0,4 m, the influence of live load is checked by measurements. A method presented in *Pettersson and Wadi (2013)* is recommended. The design soil modulus used in the calculation may be based on a back-calculated soil modulus from measurements using Eq. (b7.d).

$$E_{\text{soil,d}} = E_{\text{soil,measured}} / (2 \cdot 3) \quad (\text{b7.d})$$

where the first factor “2” is a partial safety coefficient for measured values and the second factor “3” is for converting from SLS to ULS.

The requirement $\lambda_f \leq 50\,000$ shall be fulfilled setting a limit for the maximum soil modulus to be used in the calculations.

Note that the height of cover used in the calculations should be verified by measurements for the critical sections with the lowest cover depth when the height of cover is less than 0,4 m.

B7.5 Design traffic load

B7.5.1 General

Typically standards give design load patterns for checking the capacity of existing structures. The methodology presented in Appendix 4 and applying Eqs. (b4.a) and (b4.b) the equivalent design static traffic load can be used. These load patterns for existing structures usually do not include dynamic amplification factors so these factors must be implemented.

B7.6 Special rules according to Swedish regulations

B7.6.1 Soil parameters

Typically detailed information on soil parameters are not known for existing structure. The principle of cautiousness is thus recommended. The recommended characteristic soil modulus can thus be chosen according to Eq. (b2.i). Input data according to **Table B7.1** and **Table B7.2** below is recommended for use. If however better information is at hand, due to i.e. performed geotechnical tests and evaluations, the methodology presented in **Appendix 2**, method B can be used for determining the characteristic soil modulus. Note that the design soil modulus should be calculated using partial coefficients for both material and safety class.

Fill material	Optimum unit density (kN/m ³)	Unit Density (kN/m ³)	Angle of friction (°)	Static soil pressure, K_0	C_u (d_{60}/d_{10})	d_{50} (mm)
Soil type not known	18,4	17,9	36	0,41	3,3	0,9

Table B7.1 Soil parameters for existing structure filling material when soil type is not known.

Fill material	m	β	k_v	$E_{\text{soil,k}}$
Soil type not known	1240	0,53	0,76	16,3

Table B7.2 Calculated soil parameters for existing structure filling material when soil type is not known, for $H = 2,0$ m, $h_c = 1,0$ m.

B7.6.2 Traffic load

In the Swedish standard for bridges *TDOK 2013:0267* there are special load patterns, actually 14 different, which should be used for existing bridges. All these can be combined in two design load diagrams, generated without dynamic amplification factor, giving the envelope of the maximum effect in the design of SSCB. These diagrams are shown in **Figure B7.4** and **Figure B7.5**.

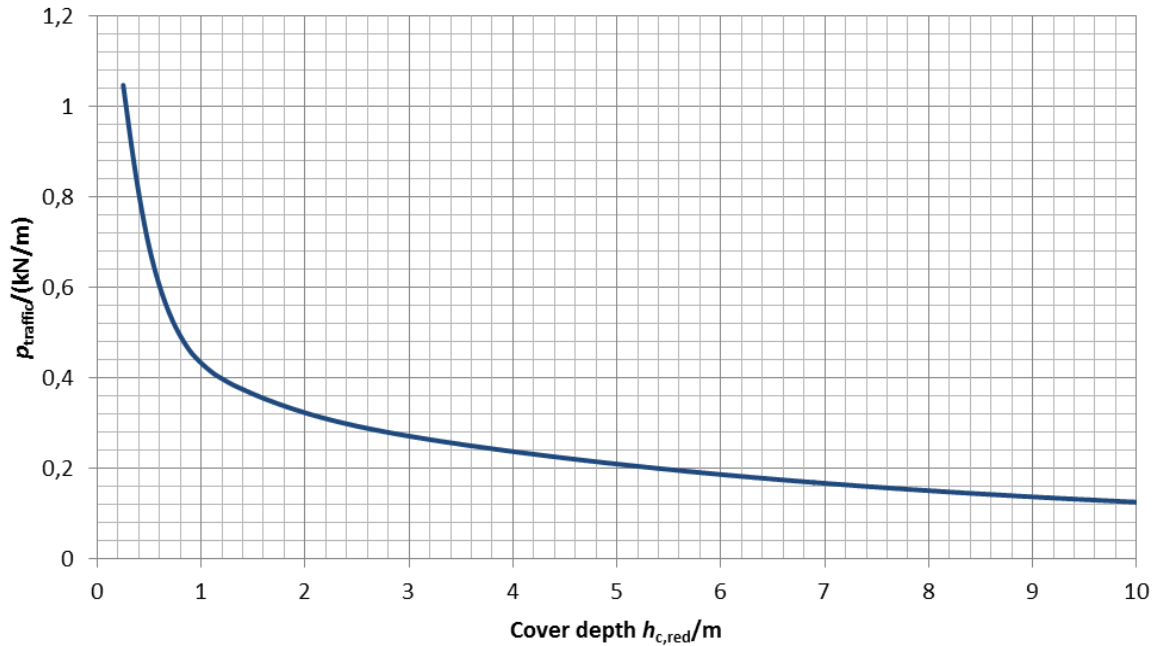

Figure B7.4 Equivalent line load calculated for *TDOK 2013:0267*, load case (a).

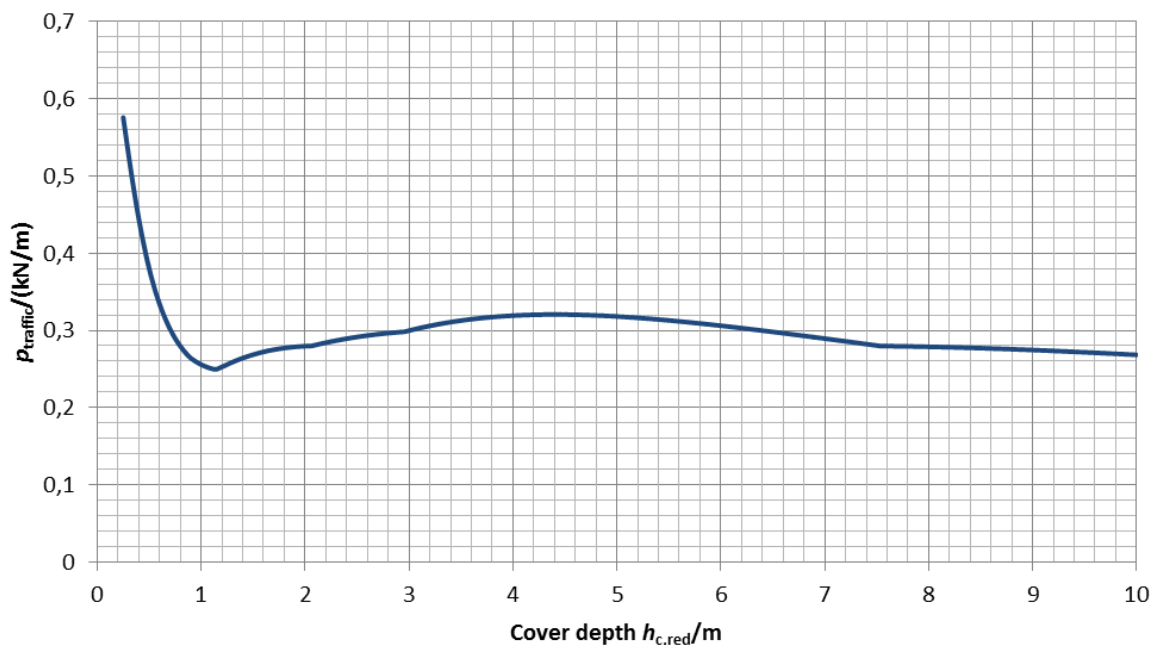

Figure B7.5 Envelope of the maximum equivalent line load calculated for *TDOK 2013:0267*, load cases b - n.

The above diagrams can be also represented by set of equations as shown in **Table B7.3** below.

Load case	$h_{c,red}$ (m)	$p_{traffic}$ (kN/m) (A & B are in kN)
(a)	$0,25 \leq h_{c,red} < 1,0$	$0,438 \cdot h_{c,red}^{-0,63} \cdot A \cdot (1 + \varepsilon)$
	$1,0 \leq h_{c,red} \leq 15,0$	$(0,987 \cdot h_{c,red}^{-0,159} - 0,557) \cdot A \cdot (1 + \varepsilon)$
(b)-(n)	$0,25 \leq h_{c,red} < 0,8$	$(0,249 \cdot h_{c,red}^{-0,605}) \cdot B \cdot (1 + \varepsilon)$
	$0,8 \leq h_{c,red} < 1,2$	$(0,007 \cdot h_{c,red}^{-6,493} + 0,249) \cdot B \cdot (1 + \varepsilon)$
	$1,2 \leq h_{c,red} < 4,0$	$(0,182 \cdot h_{c,red}^{0,238} + 0,066) \cdot B \cdot (1 + \varepsilon)$
	$4,0 \leq h_{c,red} \leq 10,0$	$(-0,008 \cdot h_{c,red}^{1,079} + 0,356) \cdot B \cdot (1 + \varepsilon)$
	$10,0 \leq h_{c,red} \leq 15,0$	$(-0,0013 \cdot h_{c,red}^{1,554} + 0,314) \cdot B \cdot (1 + \varepsilon)$

Table B7.3 Expressions for equivalent line load diagrams calculated for TDOK 2013:0267, load cases a - n pertaining to evaluation of axle load A and bogie load B.

B7.6.3 Ultimate limit state

According to Swedish regulations checking of existing structures should be done using old Swedish standards (BBK 94, BBK 04, BSK 94 and BSK07 etc.). For the ultimate limit state the expression for N/M interaction should therefore be taken as:

$$\left(\frac{N_{d,u}}{\omega f_{yd} A} \right)^{\alpha_c} + \left(\frac{M_{d,u}}{M_u} \right) \leq 1,0 \quad (b7.e)$$

In the calculation of N_{cr} in accordance with **Appendix 5**, ξ is set equal to 1. The capacity is also checked in relation to the maximum normal force and condition that $M_{d,u} = 0$, where ξ is calculated in accordance with **Appendix 5**.

The value $\omega = \frac{N_{cr}}{A f_{yd}}$ is inserted in Eq. (b7.e), where N_{cr} is calculated as indicated in **Appendix 5** and using Eqs. (b7.f), (b7.g) and (b7.h)

$$\alpha_c = \eta^2 \omega \geq 0,8 \quad (b7.f)$$

$$\eta = \frac{Z}{W} \quad (\text{b7.g})$$

For the profiles types listed in **Appendix 1**, $\eta \approx 1,35$ unless some other value is shown to be more correct.

$$M_u = Z \cdot f_{yd} \quad (\text{b7.h})$$

Where the values of Z and W are taken from **Appendix 1**. All the parameters in Eq. (b7.e) are entered as positive values.

The area and the moment of resistance are calculated with the cross-sectional values applicable to the upper part of the culverts having constant strength and stiffness values. When the corner section is checked, the relevant strength and stiffness values for these regions are entered.

For helically corrugated pipes which are cold-formed to so called low-rise profiles, Eq. (b7.e) can be used provided N_u and M_u are divided by the factor 1,15.

B7.6.4 Bolted connections

Calculation of the capacity of the bolted connections should be done using the principles in **Section 5.3.3** applying old Swedish standards (BSK 94, BSK07).

Appendix 8 – Design diagrams for different fatigue design loads

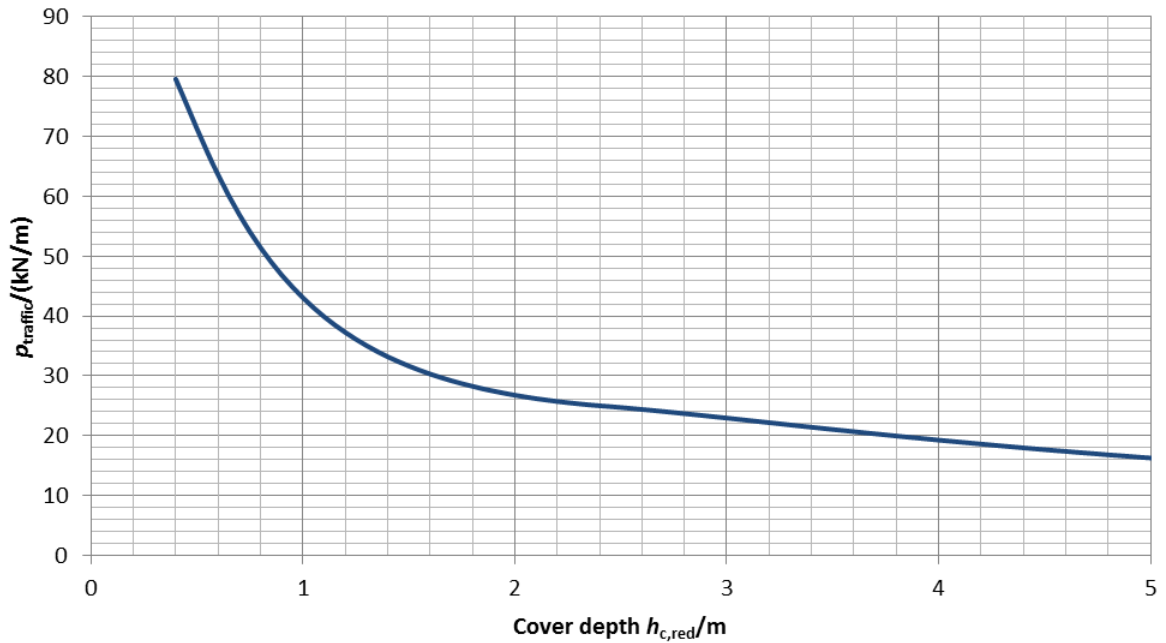

Figure B8.1 Equivalent line load calculated for one axle (120 kN) of EN 1991-2 fatigue load FLM3.

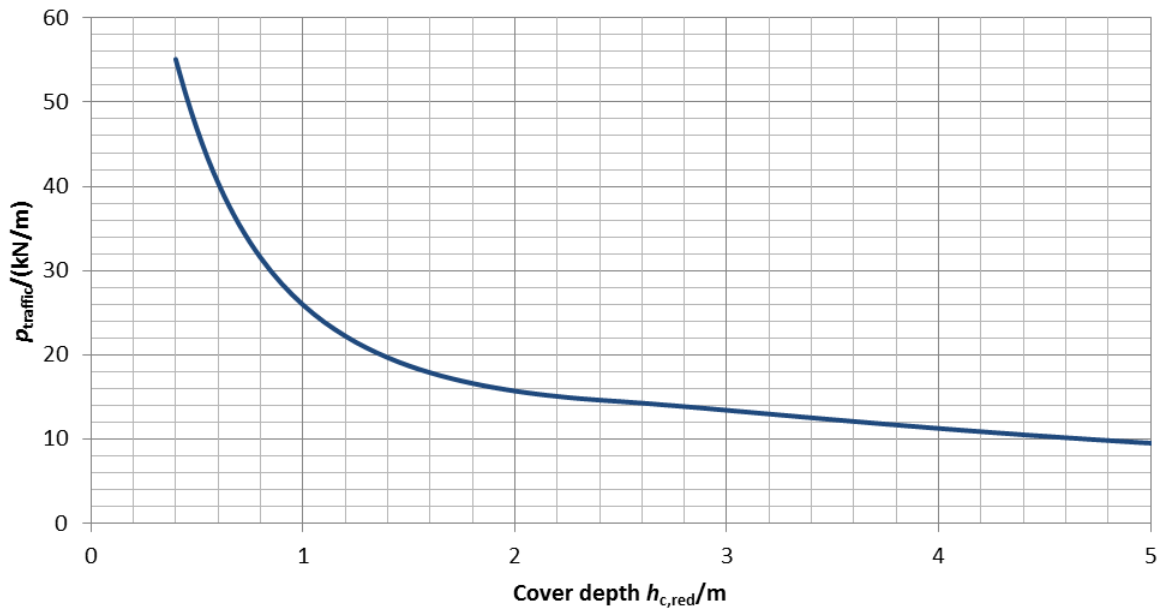

Figure B8.2 Equivalent line load calculated for axle type A (70 kN) of EN 1991-2 fatigue load FLM4.

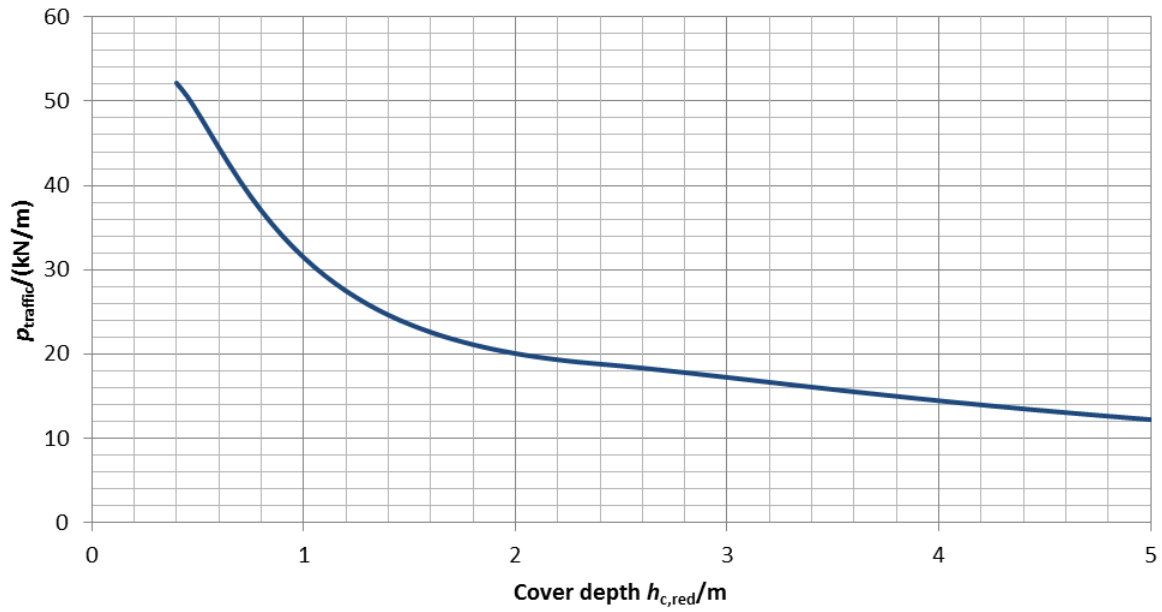

Figure B8.3 *Equivalent line load calculated for axle type B (90 kN) of EN 1991-2 fatigue load FLM4.*

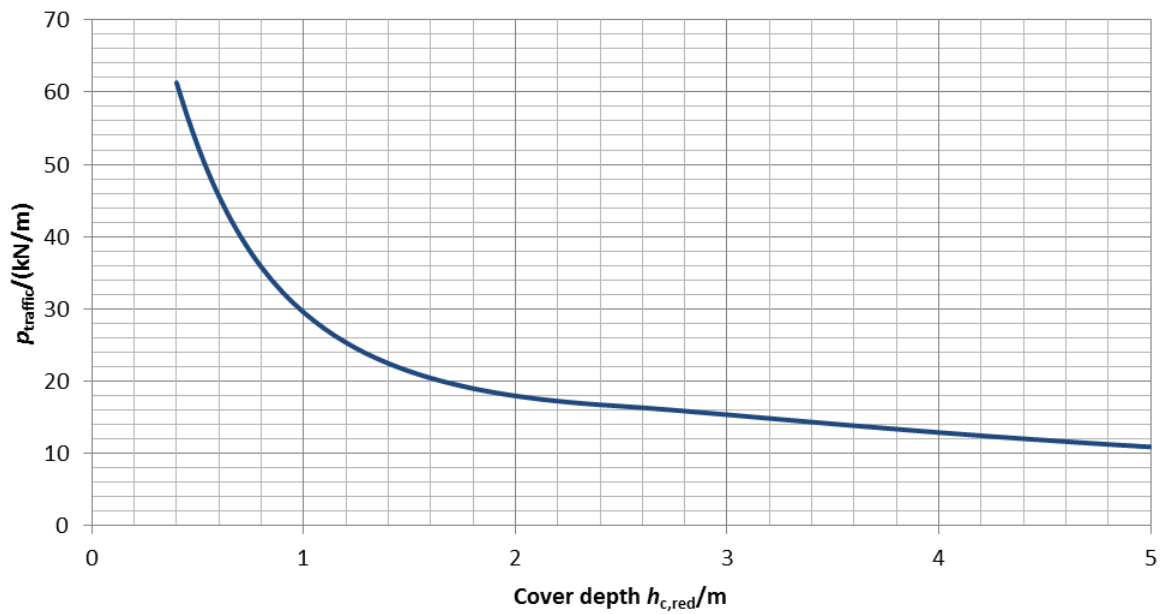

Figure B8.2 *Equivalent line load calculated for axle type C (80 kN) of EN 1991-2 fatigue load FLM4.*